



PDHonline Course C477 (5 PDH)

**FHWA Bridge Inspector's Manual
Section 4 - Bridge Inspection Reporting
System**

Instructor: Mark P. Rossow, Ph.D, PE Retired

2012

PDH Online | PDH Center

5272 Meadow Estates Drive
Fairfax, VA 22030-6658
Phone & Fax: 703-988-0088
www.PDHonline.org
www.PDHcenter.com

An Approved Continuing Education Provider

Table of Contents

Section 4	
Bridge Inspection Reporting System		
4.1	Structure Inventory	4.1.1
4.1.1	Introduction.....	4.1.1
4.1.2	FHWA Structure Inventory, Appraisal and Condition Ratings	4.1.1
	Substitutes for the SI&A Sheet.....	4.1.2
	Data Entry Requirements	4.1.2
4.1.3	Inventory Items	4.1.11
4.1.4	Appraisal Items	4.1.11
4.1.5	The Role of Inventory Items in Bridge Management Systems	4.1.12

This page intentionally left blank

Section 4

Bridge Inspection Reporting System

Topic 4.1 Structure Inventory

4.1.1

Introduction

A good bridge inspection reporting system is essential to document bridge conditions and to protect the public's safety and investment in bridge structures. It is, therefore, essential that bridge inspection data be clear, accurate, and complete, since it is an integral part of the lifelong record file of the bridge.

Because of the requirements that must be fulfilled for the National Bridge Inspection Standards (NBIS), it is necessary to employ a uniform bridge inspection reporting system. A uniform reporting system is essential to evaluate the condition of a structure correctly and efficiently. It is a valuable aid in establishing maintenance priorities and replacement priorities, and in determining structure capacity and the cost of maintaining the nation's bridges. Consequently, importance of the reporting system cannot be overemphasized. Success of any bridge inspection program is dependent upon its reporting system.

4.1.2

FHWA Structure Inventory, Appraisal and Condition Ratings

The FHWA *Recording and Coding Guide for the Structure Inventory and Appraisal of the Nation's Bridges (Coding Guide)* is used for establishing the bridge inventory and the overall condition of the deck, superstructure, substructure, and channel. The data must be reported using FHWA established procedures as outlined in the *Coding Guide*. It is not an inspection guide. Each state may use its own coding scheme, provided that the data is directly translatable into the format of the *Coding Guide*. In other words, the states are responsible for having the capability to obtain, store, and report certain information about bridges, for collection by FHWA as requested.

The Structure Inventory and Appraisal (SI&A) sheet is a tabulation of information that must be submitted for each individual structure (see Figure 4.1.1). Any requests by the FHWA for submittals of SI&A data will be based on the definitions, explanations, and codes supplied in this manual, its supplements, and the *Coding Guide* with interim changes or the most recent version.

Sometimes inventory data is not available for new or small bridges and culverts. For the small bridges and culverts that are less than 20 feet, some states still collect

the inventory information and generate a “local” database. The inspector must gather enough information in order to establish inventory data.

It is important to note that the SI&A sheet is not an inspection form. Rather, it is a summary sheet of bridge data required by the FHWA to effectively monitor and manage the National Bridge Inspection Program and the Highway Bridge Program.

Substitutes for the SI&A Sheet NBIS allows the use of suitable substitutes for the SI&A sheet. The only requirement is that the forms must be standardized. Some states simply reprint the federal form with the same items and item numbers. A few states have elaborate Bridge Management Systems (BMS) with different item numbers that collect all the data listed on the SI&A form plus additional items not reported to the FHWA (see Figures 4.1.1, 4.1.2 and 4.1.3).

Data Entry Requirements For routine, in-depth, fracture critical member, underwater, damage and special inspections enter the SI&A data into the State or Federal agency inventory within 90 days of the date of inspection for State or Federal agency bridges and within 180 days of the date of inspection for all other bridges.

For existing bridge modifications that alter previously recorded data and for new bridges, enter the SI&A data into the State or Federal agency inventory within 90 days after the completion of the work for State or Federal agency bridges and within 180 days after the completion of the work for all other bridges.

For changes in load restriction or closure status, enter the SI&A data into the State or Federal agency inventory within 90 days after the change in status of the structure for State or Federal agency bridges and within 180 days after the change in status of the structure for all other bridges.

Appendix A

OMB No. 2125-0501

Structure Inventory and Appraisal Sheet

NATIONAL BRIDGE INVENTORY - - - - - STRUCTURE INVENTORY AND APPRAISAL 10/15/94

***** IDENTIFICATION *****

(1) STATE NAME - _____ CODE _____
 (8) STRUCTURE NUMBER _____ # _____
 (5) INVENTORY ROUTE (ON/UNDER) - _____ = _____
 (2) HIGHWAY AGENCY DISTRICT _____
 (3) COUNTY CODE _____ (4) PLACE CODE _____
 (6) FEATURES INTERSECTED - _____
 (7) FACILITY CARRIED - _____
 (9) LOCATION - _____
 (11) MILEPOINT/KILOMETERPOINT _____
 (12) BASE HIGHWAY NETWORK - _____ CODE _____
 (13) LRS INVENTORY ROUTE & SUBROUTE # _____
 (16) LATITUDE _____ DEG _____ MIN _____ SEC
 (17) LONGITUDE _____ DEG _____ MIN _____ SEC
 (98) BORDER BRIDGE STATE CODE _____ % SHARE _____ %
 (99) BORDER BRIDGE STRUCTURE NO. # _____

***** STRUCTURE TYPE AND MATERIAL *****

(43) STRUCTURE TYPE MAIN: MATERIAL - _____
 TYPE - _____ CODE _____
 (44) STRUCTURE TYPE APPR: MATERIAL - _____
 TYPE - _____ CODE _____
 (45) NUMBER OF SPANS IN MAIN UNIT _____
 (46) NUMBER OF APPROACH SPANS _____
 (107) DECK STRUCTURE TYPE - _____ CODE _____
 (108) WEARING SURFACE / PROTECTIVE SYSTEM:
 A) TYPE OF WEARING SURFACE - _____ CODE _____
 B) TYPE OF MEMBRANE - _____ CODE _____
 C) TYPE OF DECK PROTECTION - _____ CODE _____

***** AGE AND SERVICE *****

(27) YEAR BUILT _____
 (106) YEAR RECONSTRUCTED _____
 (42) TYPE OF SERVICE: ON - _____
 UNDER - _____ CODE _____
 (28) LANES: ON STRUCTURE _____ UNDER STRUCTURE _____
 (29) AVERAGE DAILY TRAFFIC _____
 (30) YEAR OF ADT _____ (109) TRUCK ADT _____ %
 (19) BYPASS, DETOUR LENGTH _____ KM

***** GEOMETRIC DATA *****

(48) LENGTH OF MAXIMUM SPAN _____ M
 (49) STRUCTURE LENGTH _____ M
 (50) CURB OR SIDEWALK: LEFT _____ M RIGHT _____ M
 (51) BRIDGE ROADWAY WIDTH CURB TO CURB _____ M
 (52) DECK WIDTH OUT TO OUT _____ M
 (32) APPROACH ROADWAY WIDTH (W/SHOULDERS) _____ M
 (33) BRIDGE MEDIAN - _____ CODE _____
 (34) SKEW _____ DEG (35) STRUCTURE FLARED _____
 (10) INVENTORY ROUTE MIN VERT CLEAR _____ M
 (47) INVENTORY ROUTE TOTAL HORIZ CLEAR _____ M
 (53) MIN VERT CLEAR OVER BRIDGE RDWY _____ M
 (54) MIN VERT UNDERCLEAR REF - _____ M
 (55) MIN LAT UNDERCLEAR RT REF - _____ M
 (56) MIN LAT UNDERCLEAR LT _____ M

***** NAVIGATION DATA *****

(38) NAVIGATION CONTROL - _____ CODE _____
 (111) PIER PROTECTION - _____ CODE _____
 (39) NAVIGATION VERTICAL CLEARANCE _____ M
 (116) VERT-LIFT BRIDGE NAV MIN VERT CLEAR _____ M
 (40) NAVIGATION HORIZONTAL CLEARANCE _____ M

***** CLASSIFICATION *****

(112) NBIS BRIDGE LENGTH - _____
 (104) HIGHWAY SYSTEM - _____
 (26) FUNCTIONAL CLASS - _____
 (100) DEFENSE HIGHWAY - _____
 (101) PARALLEL STRUCTURE - _____
 (102) DIRECTION OF TRAFFIC - _____
 (103) TEMPORARY STRUCTURE - _____
 (105) FEDERAL LANDS HIGHWAYS - _____
 (110) DESIGNATED NATIONAL NETWORK - _____
 (20) TOLL - _____
 (21) MAINTAIN - _____
 (22) OWNER - _____
 (37) HISTORICAL SIGNIFICANCE - _____

***** CONDITION *****

(58) DECK _____
 (59) SUPERSTRUCTURE _____
 (60) SUBSTRUCTURE _____
 (61) CHANNEL & CHANNEL PROTECTION _____
 (62) CULVERTS _____

***** LOAD RATING AND POSTING *****

(31) DESIGN LOAD - _____ OR _____
 (63) OPERATING RATING METHOD - _____
 (64) OPERATING RATING - _____
 (65) INVENTORY RATING METHOD - _____
 (66) INVENTORY RATING - _____
 (70) BRIDGE POSTING - _____
 (41) STRUCTURE OPEN, POSTED OR CLOSED - _____
 DESCRIPTION - _____

***** APPRAISAL *****

(67) STRUCTURAL EVALUATION _____
 (68) DECK GEOMETRY _____
 (69) UNDERCLEARANCES, VERTICAL & HORIZONTAL _____
 (71) WATERWAY ADEQUACY _____
 (72) APPROACH ROADWAY ALIGNMENT _____
 (36) TRAFFIC SAFETY FEATURES _____
 (113) SCOUR CRITICAL BRIDGES _____

***** PROPOSED IMPROVEMENTS *****

(75) TYPE OF WORK - _____ CODE _____
 (76) LENGTH OF STRUCTURE IMPROVEMENT _____ M
 (94) BRIDGE IMPROVEMENT COST \$ _____,000
 (95) ROADWAY IMPROVEMENT COST \$ _____,000
 (96) TOTAL PROJECT COST \$ _____,000
 (97) YEAR OF IMPROVEMENT COST ESTIMATE _____
 (114) FUTURE ADT _____
 (115) YEAR OF FUTURE ADT _____

***** INSPECTIONS *****

(90) INSPECTION DATE ____/____/____ (91) FREQUENCY _____ MO
 (92) CRITICAL FEATURE INSPECTION: (93) CFI DATE
 A) FRACTURE CRIT DETAIL - _____ MO A) ____/____/____
 B) UNDERWATER INSP - _____ MO B) ____/____/____
 C) OTHER SPECIAL INSP - _____ MO C) ____/____/____

Figure 4.1.2 FHWA SI&A Sheet with NBI Data Only

BRIDGE GROUP

Structure Inventory & Appraisal

Structure Number: 4023		Structure Name: RCB		Feature Under: WASH	
Route: 60 MP 56.85		Road Name: US 60		Location: 7.3 M E JCT SR 72	
		Agency: ADOT			

LOCATION INFORMATION		DIMENSIONS		PROPOSED IMPROVEMENTS	
N1-State Code:	049	N32-Appr Rdwy Width (feet):	36	N75-Type of Work:	
N2-State Hwy District:	88	N48-Max Span Length (feet):	10	N76-Length of Str Imp (feet):	0
N3-County Code:	029	N49-Structure Length (feet):	32	N94-Br Improv Cost (x1000):	\$0
N4-Place Code:	00000	N50a-Lt Curb/Swlk Width (feet):	1	N95-Rdwy Improv Cost (x1000):	\$0
N16-Latitude:	33 deg 47.1 min	N50b-Rt Curb/Swlk Width (feet):	1	N96-Total Project Cost (x1000):	\$0
N17-Longitude:	113 deg 36.5 min	N51-Br Width Curb-Curb (feet):	39	N97-Year of Cost Estimate:	
N98-Border St Code - % Resp:	- 0	N52-Deck Width Out-Out (feet):	41.6		
N99-Border Bridge Number:		N112-NBIS Br Length?	Y		

INVENTORY ROUTE DATA		VERTICAL and HORIZONTAL CLEARANCE		CONSTRUCTION PROJECT DATA	
N19-Detour Length (miles):	20	N53-Min Vert Over Clr (feet):	99.99	N27-Year Built:	1958
N20-Toll:	3	N54-Min Vert Under Clr (feet):	N 0	N106-Year of Reconstruction:	0000
N28-Lanes On / Under:	2 / 0	N55-Min Lat Under Clr Rt (feet):	N 99.9	A204-Orig Project Number:	F-022-1(1)
	<i>2nd Record</i>	N56-Min Lat Under Clr Lt (feet):	0	A205-Orig Project Station:	3045+14.34
N5-Inv Rte:	1 2 0 00060 0 -			A223-TRACS Number:	
N10-Inv Rte Min Vert Clr (feet):	99.99			A225-Deck Area (sq. feet):	0
N11-Inv Rte Milepoint:	56.85			A226-Superstr Unit Cost:	\$0
N26-Functional Class:	07			A227-Substr Unit Cost:	\$0
N29-Avg Daily Traffic:	2417				
N30-Year of ADT:	1998				
N47-Inv Rte Tot Horiz Clr (feet):	39				
N100-Defense Hwy:	0				
N101-Parallel Bridge:	N				
N102-Direction of Traffic:	2				
N104-Hwy System:	0				
N109-Percent Truck Traffic:	46				
N110-National Truck Network:	1				
N114-Future ADT:	2427				
N115-Year of Future ADT:	2020				
N200-Is N5 the Princ. Rte?:	Y				

RESPONSIBILITY		SERVICE, TYPE, and SPAN INFORMATION		INSPECTION	
I21-Maint Responsibility:	01	N42-Service Type:	15	N90-Inspection Date:	2/1/2000
I22-Bridge Owner:	01	N43-Str Type, Main:	219	N91-Insp Freq (months):	48
I203-ADOT Org Number:	8852	N44-Str Type, Appr:	000	A207-Inspection Quarter:	1
I224-Insp Team Number:	4	N45-Number of Main Spans:	3	A208-Inspection Number:	14
I229-Agency:	ADOT	N46-Number of Appr Spans:	0	A228-Next Insp Date:	Quarter 1, 2004

NAVIGATION		CONDITION RATINGS		CRITICAL FEATURES	
I38-Navigation Control:	0	N58-Deck:	8	N92A-Fracture Critical:	N 0
I39-Nav Vert Clr (feet):	0	N59-Superstructure:	N	N92B-Underwater Insp:	N 0
I40-Nav Horiz Clr (feet):	0	N60-Substructure:	N	N92C-Special Insp:	N 0
I11-Nav Pier/Abut Prot:		N61-Channel:	7	N93A-Date Fract Crit Insp:	0
I16-Nav Min Vert Clr (feet):	0	N62-Culvert:	7	N93B-Date Underwtr Insp:	0
				N93C-Date Spec Insp:	0
				A234-Steel In-Depth Insp Freq (mo):	0

GENERAL DATA		APPRAISAL RATINGS		CULVERT INFORMATION	
I33-Bridge Median:	0	N67-Struct Evaluation:	7	A217-Culv Barrel Height (feet):	6
I34-Skew:	0	N68-Deck Geometry:	5	A218-Culv Length (feet):	41
I35-Structure Flared:	0	N69-Underclearance Rtg:	N	A219-Culv Fill Height (feet):	1
I37-Historical Significance:	5	N71-Waterway Adequacy:	6		
I107-Deck Str Type:	1	N72-Appr Rdw Align:	8		
I108-Wear Surf Prot System:	6 0 0	N36-Traffic Safety Features:	0 0 0 0		
I201-Wear Surf Thickness (inches):	4				

BRIDGE SCOUR DATA		LOAD RATE, and POST		SUFFICIENCY RATING	
N113-Scour Critical Rtg:	8	N31-Design Loading:	5	Sufficiency Rating:	92.32
A202-Foundation Type:		N41-Open, Post, Close:	A		
A220-Found Embed (feet):	0	N63-Method Used for Oper. Rtg.:	5		
A221-Scour Countermeasure:	0 1 0	N64-Operating Load Rtg:	2 - 36		
		N65-Method Used for Inv. Rtg.:	5		
		N66-Inventory Load Rtg:	2 - 36		
		N70-Bridge Posting:	5		
		N103-Temp Str Designation:			
		A211-Posted Limit (Tons):	0		
		A222-Date of Load Rtg:			
		A233-Posted Vert Clr NB/EB (ft-in):	0 - 0		
		A233-Posted Vert Clr SB/WB (ft-in):	0 - 0		

GENERAL COMMENTS	

Figure 4.1.3 Arizona Structural Inventory and Appraisal Sheet

Structure ID: 520002

4 Description

Structure Unit Identification

Bridge/Unit ID 520002 0
 Description MAIN SPAN 1
 Type Main Span
 NBI Unit Flag Main Approach
 Curb/Sidewalk (50) Left 0 ft Right 0 ft
 Deck width (52) 0 ft
 Bridge Median (33) No median

Roadway Identification:

NBI Structure No (8) 520002
 Position/Prefix (5) Route On Structure
 Kind Hwy (Rte Prefix) U.S. Numbered Hwy
 Design Level of Service Mainline
 Route Number/Suffix 00090 / Not Applicable
 Feature Intersect (6) US90 SR10/GUM CREEK
 Critical Facility Not Defense-crit
 Facility Carried (7) US 90 SR 10
 Mile Point (11) 20.815
 Latitude (16) 030d47'39" Long (17) 085d43'28"

Roadway Classification

Nat. Hwy Sys (104) Not on NHS
 National base Net (12) On Base Network
 LRS Inventory Rte (13a) 52 010 000 Sub Rte (13b) 00
 Functional Class (26) Rural Minor Arterial
 Eligible for Federal Aid ? Yes
 Defense Hwy (100) Not a STRAHNET hwy
 Direction of Traffic (102) 2-way traffic
 Critical Travel Route

Structure Unit Type and Material

Struct Material (43) Concrete
 Design Type Culvert
 Deck Type (107) Not Applicable
 Surface (108) Not Applicable
 Membrane None
 Deck Protection None
 Skew (34) 0 deg

Roadway Traffic and Accidents

Lanes (28) 2 Medians 0 Speed 54.681 mph
 ADT Class ADT Class 3
 Recent ADT (29) 5100 Year (30) 1998
 Future ADT (114) 9490 Year (115) 2020
 Truck % ADT (109) 7
 Detour Length (19) 1.243 mi
 Detour Speed 44.739 mph
 Accident Count -1 Rate -1

Roadway Clearances

Vertical (10) 99.99 ft Appr. Road (32) 34.121 ft
 Horiz. (47) 34.121 ft Roadway (51) 0 ft
 Truck Network (110) Not part of natl network
 Toll Facility (20) On free road
 Fed. Lands Hwy (105) Not Applicable
 School Bus Route
 Transit Route

Figure 4.1.4 Florida Structural Inventory and Appraisal Sheet

REPORT ID: INVT001A

FLORIDA DEPARTMENT OF TRANSPORTATION
 BRIDGE MANAGEMENT SYSTEM
 COMPREHENSIVE INVENTORY DATA REPORT

Page 2 of 4

Structure ID: 520002

Structure Identification

Admin Area Not located in area
 District (2) D3 - Chipley
 County (3) (52)Holmes
 Place Code (4) No city involved
 Location (9) 3.2 KM W OF BONIFAY
 Border Br St/Reg (98) Not Applicable Share 0 %
 Border Struct No (99)
 FIPS State/Region (1) Florida Region 4-Atlanta
 NBIS Bridge Len (112) Meets NBI Length
 Parallel Structure (101) No ll bridge exists
 Temp. Structure (103) Not Applicable
 Maint. Resp. (21) State Highway Agency
 Owner (22) State Highway Agency
 Historic Signif. (37) Not eligible for NRHP

Geometrics

Spans in Main Unit (45) 4
 Approach Spans (46) 0
 Length of Max Span (48) 9.843 ft
 Structure Length (49) 42.979 ft
 Deck Area -1 sqft
 Structure Flared (35) No flare

Age and Service

Year Built (27) 1954
 Year Reconstructed (106) -1
 Type of Service On (42a) Highway
 Under (42b) Waterway
 Fracture Critical Details Not Applicable

3 Appraisal

Structure Appraisal

Open/Posted/Closed (41) Open, no restriction
 Deck Geometry (68) Not Applicable
 Underclearances (69) Not Applicable
 Approach Alignment (72) No speed red thru curve
 Bridge Railings (36a) Not Applicable
 Transitions (36b) Not Applicable
 Approach Guardrail (36c) Meets Standards
 Approach Guardrail ends (36d) Meets Standards
 Scour Critical (113) Stable Above Footing

Navigation Data

Navigation Control (38) Permit Not Required
 Nav Vertical Clr (39) 0 ft
 Nav Horizontal Clr (40) 0 ft
 Min Vert Lift Clr (116) 0 ft
 Pier Protection (111) Not Applicable

NBI Condition Rating

Sufficiency Rating * 99.5
 Structural Eval (67) Above Min Criteria
 Deficiency Not Deficient

Minimum Vertical Clearance

Over Structure (53) 99.99 ft
 Under (reference) (54a) Feature not hwy or RR
 Under (54b) 0 ft

Minimum Lateral Underclearance

Reference (55a) Feature not hwy or RR
 Right Side (55b) 0 ft
 Left Side (56) 0 ft

Load Rating

Design Load (31) M 13.5 (H 15)
 Rating Date 08/08/1994 Initials JF
 Posting (70) At/Above Legal Loads

Operating Type (63) LF Load Factor
 Operating rating (64) 68.894 tons Alternate -1
 Inventory Type (65) LF Load Factor
 Inventory Rating (66) 40.896 tons Alternate -1
 Alt Meth -1

6 Schedule

Current Inspection

Inspection Date 01/06/2000
 Inspector MT338TK - Tom Klopfenstein
 Primary Type Regular NBI
 Review Required

Next Inspection Date Scheduled

NBI 01/06/2002
 Element 01/06/2002
 Fracture Critical
 Underwater
 Other Special

Inspection Types

Performed NBI Element Fracture Critical Underwater Other Special

Figure 4.1.4 Florida Structural Inventory and Appraisal Sheet (Continued)

Structure ID: 520002

<u>Inspection Intervals</u>	<u>Required (92)</u>	<u>Frequency (92)</u>	<u>Last Date (93)</u>	<u>Inspection Resources</u>
Fracture Critical <input type="checkbox"/>		mos		Crew Hours 8
Underwater <input type="checkbox"/>		mos		Flagger Hours 0
Other Special <input type="checkbox"/>		mos		Helper Hours 0
NBI		24 mos (91)	01/06/2000 (90)	Snooper Hours 0
				Special Crew Hours 0
				Special Equip Hours 0

5 Custom

General Bridge Information

Parallel Bridge Seq	Bridge Rail 1 Not applicable-No rail
Channel Depth 0.328 ft	Bridge Rail 2 Not applicable-No rail
Radio Frequency -1	Electrical Devices No electric service
Phone Number (000) 000-0001	Culvert Type Not applicable
Exception Date	Maintenance Yard Marianna Yard
Exception Type Unknown	

Bridge Load Rating Information

Govr. Span Length 9.843 ft	Single Unit Truck 2 Axles 48.502 tons
L-Rating Origination Design Plans	Single Unit Truck 3 Axles 60.627 tons
Load Rating Date 08/08/1994	Single Unit Truck 4 Axles 74.957 tons
Method Calculation AASHTO formula	Combination Unit Truck 3 Axles 79.366 tons
Load Dist. Factor 0.168	Combination Unit Truck 4 Axles 79.366 tons
Impact Factor 0	Combination Unit Truck 5 Axles 87.083 tons
Design Method Load Factor	Truck Trailer 5 Axles 95.901 tons
Design Measure English	Posting Weight tons
Recommended Single Unit -1 tons	Posting Single Unit -1 tons
Recommended Combination -1 tons	Posting Combination Unit -1 tons
Recommended Tandem -1 tons	Posting Tandem Unit -1 tons

Bridge Scour and Storm Information

Pile Driving Record Not Applicable	Scour Recommended I Stop scour evaluations
Foundation Type Foundation details	Scour Recommended II Unknown
Mode of Flow Riverine	Scour Recommended III Unknown
Rating Scour Eval Low Risk - Low	Scour Elevation -1 ft
Highest Scour Eval Phase I completed	Action Elevation -1 ft
	Storm Frequency -1

1 Condition

NBI Rating

Channel (61) No Deficiencies	Culvert (62) Minor Deterioration
Deck (58) Not Applicable	Waterway (71) 8 - Equal Desirable
Superstructure (59) Not Applicable	Unrepaired Spalls -1 sq.ft.
Substructure (60) Not Applicable	Review Required <input type="checkbox"/>

Figure 4.1.4 Florida Structural Inventory and Appraisal Sheet (Continued)

REPORT ID: INVT001A

FLORIDA DEPARTMENT OF TRANSPORTATION
 BRIDGE MANAGEMENT SYSTEM
 COMPREHENSIVE INVENTORY DATA REPORT

Page 4 of 4

Structure ID: 520002

Elements

Inspection Date: 01/06/2000 GKXW

Span Id	Elem/Er	Description	Qty1	%1	Qty2	%2	Qty3	%3	Qty4	%4	Qty5	%5	T Qty
0	290/4	Channel	1	100	0	0	0	0	0	0	0	0	1 ea.

Notes

0	475/4	R/Conc Walls	154	100	0	0	0	0	0	0	0	0	154 lf.
---	-------	--------------	-----	-----	---	---	---	---	---	---	---	---	---------

Notes

0	241/4	Concrete Culvert	299	82	66	18	0	0	0	0	0	0	364 lf.
---	-------	------------------	-----	----	----	----	---	---	---	---	---	---	---------

Notes There are a few vertical cracks in the side walls of the original section of culvert.

Total Number of Elements: 3

Past Inspections

Inspection Date: 01.06.2000

Type: Regular NBI

Inspector: MT338TK - Tom Klopfenstein

Inspection Notes: Sufficiency Rating Calculation Accepted by mt338tk at 01/10/2000 13:45:43
 MT338TK inspection comments - The left extended portion of culvert is skewed 24 degrees to the left due to stream alignment.
 Structure 520002 -
 Date 01/06/2000 -
 Previous comments > (none)

Inspection Date: 04.01.1998

Type: Regular NBI

Inspector: BID

Inspection Notes:

Bridge Notes

Figure 4.1.4 Florida Structural Inventory and Appraisal Sheet (Continued)

Some agencies furnish standardized sketch sheets and photo sheets to inspectors for report generation. Some agencies have developed their forms on software packages for use on portable computers or wearable computers (see Figures 4.1.5 and 4.1.6).



Figure 4.1.5 Wearable Computer with Case



Figure 4.1.6 Inspector Using Wearable Computer

The data and information required of states by the FHWA is listed on the SI&A sheet. It is important to note that the items listed on this sheet apply to both the field and office personnel responsible for bridge inspections. The bridge inspector is not required to obtain the data for all the items during every inspection of a bridge. Once a bridge has been inventoried, the majority of the SI&A items will remain unchanged. The inspector should spot check to see if inventoried items are consistent with findings from the bridge site.

4.1.3

Inventory Items

Inventory items pertain to a bridge's characteristics. For the most part, these items are permanent characteristics, which only change when the bridge is altered in some way, such as reconstruction or load restriction. Inventory items include the following SI&A items:

- Identification – Identifies the structure using location codes and descriptions.
- Structure Type and Material – Categorizes the structure based on the material, design and construction, the number of spans, and wearing surface.
- Age and Service – Information showing when the structure was constructed or reconstructed, features the structure carries and crosses, and traffic information.
- Geometric Data – Includes pertinent structural dimensions.
- Navigation Data – Identifies the existence of navigation control, pier protection, and waterway clearance measurements.
- Classification – Classification of the structure and the facility carried by the structure are identified.
- Load Rating and Posting – Identifies the load capacity of the bridge and the current posting status.
- Proposed Improvements – Items for work proposed and estimated costs for all bridges eligible for funding from the Highway Bridge Program, and other structures the highway agency chooses to include.
- Inspection – Includes latest inspection dates, designated frequency, and critical features requiring special inspections or special emphasis during inspection.

All inventory items are explained in the *Coding Guide*. Although inventory items are usually provided from previous reports, the inspector must be able to verify and update the inventory data needed. See Topic 4.2 for condition and appraisal rating items.

4.1.4

Appraisal Items

Appraisal items are a judgment of a bridge component condition in comparison to current standards. Appraisal items are used to evaluate the structure based on the level of service it provides on the highway system. Appraisal rating items include the following SI&A items:

- Condition Rating Items – Current physical state compared to what it was the day it was built. The ability of the element, member or component to

carry legal loads is not to be considered.

- Structural Evaluation – Overall condition of the structure based on all major deficiencies, and its ability to carry loads.
- Deck Geometry – Evaluates the curb-to-curb bridge roadway width and the minimum vertical clearance over the bridge roadway.
- Under-clearances, Vertical and Horizontal – The vertical and horizontal under-clearances from the through roadway under the structure to the superstructure or substructure units.
- Waterway Adequacy – Appraises waterway opening with respect to passage of flow under the bridge.
- Approach Roadway Alignment – Comparing the alignment of the bridge approaches to the general highway alignment of the section of highway that the structure is on.
- Traffic Safety Features – Record information on bridge railings, transitions, approach guiderail, approach guiderail ends, so that evaluation of their adequacy can be made.
- Scour Critical Bridges – Identify the current status of the bridge regarding its vulnerability to scour.

4.1.5

The Role of Inventory Items in Bridge Management Systems

Inventory items are an important part of an owner's Bridge Management System (BMS). Bridge owners use the inventory items to help plan inspection, maintenance, and reconstruction of their bridges, as well as sort their bridges. There have been times when there has been a problem on a particular bridge and the owners used the inventory items of that bridge to search for the same potential problems that might exist on other bridges.

Table of Contents

Section 4	
Bridge Inspection Reporting System		
4.2	Condition and Appraisal	4.2.1
4.2.1	Introduction.....	4.2.1
4.2.2	Condition Rating Items	4.2.1
	Bridge Components and Elements	4.2.1
	Evaluating Elements.....	4.2.1
	Evaluating Components.....	4.2.1
	Condition Rating Guidelines	4.2.2
	Condition State Assessment	4.2.6
4.2.3	Appraisal Rating Items.....	4.2.6
	Appraisal Rating Guidelines.....	4.2.6
4.2.4	Maintenance Rating Guidelines	4.2.9
4.2.5	Overall Culvert Ratings	4.2.11
	General	4.2.11
	Overall Condition	4.2.11
	Load-carrying Capacity	4.2.11
	Remaining Life.....	4.2.11
4.2.6	Functionally Obsolete and Structurally Deficient.....	4.2.12
	Definitions	4.2.12
	General Qualifications.....	4.2.12
4.2.7	Sufficiency Rating	4.2.13
	Definition.....	4.2.13
	Sufficiency Rating Formula	4.2.13
	Uses	4.2.13

This page intentionally left blank

Topic 4.2 Condition and Appraisal

4.2.1

Introduction

The reported condition of an element or component is an evaluation of its current physical state compared to what it was on the day it was built. Appraisal rating items are used to evaluate a bridge in relation to the level of service it provides on the highway system of which it is a part.

4.2.2

Condition Rating Items

Bridge Components and Elements

Accurate assignment of condition ratings is dependent upon the bridge inspector's ability to identify the bridge components and their elements. Bridge components are the major parts comprising a bridge including the deck, superstructure, substructure, channel and channel protection, and culverts. Bridge elements are individual members comprised of basic shapes and materials connected together to form bridge components.

The overall condition rating of bridge components is directly related to the physical deficiencies of bridge elements.

Evaluating Elements

The inspector should evaluate each element of a each component and assign to it a descriptive condition rating of "good," "fair," or "poor," based on the physical deficiencies found on the individual element. The following guidelines should be used in establishing an element's condition rating:

- Good - element is limited to only minor problems.
- Fair - structural capacity of element is not affected by minor deterioration, section loss, spalling, cracking, or other deficiency.
- Poor/Critical - structural capacity of element is affected or jeopardized by advanced deterioration, section loss, spalling, cracking, or other deficiency.

To ensure a comprehensive inspection and as a part of the requirements of record keeping and documentation, an inspector should record the location, type, size, quantity, and severity of deterioration and deficiencies for each element of a given component.

Evaluating Components

The following Structure Inventory and Appraisal (SI&A) items receive an overall condition rating:

- Item No. 58 – Deck
- Item No. 59 – Superstructure
- Item No. 60 – Substructure
- Item No. 61 – Channel and Channel Protection
- Item No. 62 – Culverts

Items 58 through 60 are major components of bridges. Item 62 and the inspection of culverts is discussed in Topics 7.12, 12.3, and 12.4. Item 61 is used only for

structures over waterways.

Condition Rating Guidelines

Numerical condition ratings should characterize the general condition of the entire component being rated. They should not attempt to describe localized or nominally occurring instances of deterioration or disrepair. Correct assignment of a condition rating must, therefore, consider both the severity of the deterioration or disrepair and the extent to which it is widespread throughout the component being rated. Condition ratings assigned to elements of a component must be combined to establish the overall component condition rating.

If the bridge has multiple spans, the inspector must evaluate all elements both quantitatively and qualitatively. However, in some cases, a deficiency will occur on a single element or in a single location. If that one deficiency reduces the load carrying capacity or serviceability of the component, the element can be considered a "weak link" in the structure, and the rating of the component should not be reduced. If there is a localized occurrence of deterioration, the bridge owner should be contacted. The localized defect could be described to the owner with possible retrofit or repair actions.

The following general condition rating guidelines (obtained from the 1995 edition of the *Coding Guide*) are to be used in the evaluation of the deck, superstructure, and substructure:

<u>Code</u>	<u>Description</u>
N	NOT APPLICABLE
9	EXCELLENT CONDITION
8	VERY GOOD CONDITION - no problems noted.
7	GOOD CONDITION - some minor problems.
6	SATISFACTORY CONDITION - structural elements show some minor deterioration.
5	FAIR CONDITION - all primary structural elements are sound but may have minor section loss, cracking, spalling, or scour.
4	POOR CONDITION - advanced section loss, deterioration, spalling, or scour.
3	SERIOUS CONDITION - loss of section, deterioration, spalling, or scour have seriously affected primary structural components. Local failures are possible. Fatigue cracks in steel or shear cracks in concrete may be present.
2	CRITICAL CONDITION - advanced deterioration of primary structural elements. Fatigue cracks in steel or shear cracks in concrete may be present or scour may have removed substructure support. Unless closely monitored it may be necessary to close the bridge until corrective action is taken.
1	"IMMINENT" FAILURE CONDITION - major deterioration or section loss present in critical structural components, or obvious vertical or horizontal movement affecting structure stability. Bridge is closed to traffic but corrective action may put bridge back in light service.
0	FAILED CONDITION - out of service; beyond corrective action.

The condition rating guidelines presented above are general in nature and can be applied to all bridge components and material types. Additional component specific condition rating guidelines are provided for Item 61, Channel and Channel Protection, and for Item 62, Culverts. (These component specific guidelines are shown below.) Rate and code the condition for Item 61 and Item 62 using the specific condition rating guidelines in accordance with the previously noted general condition rating guidelines.

Item 61 – Channel and Channel Protection

This item describes the physical conditions associated with the flow of water through the bridge such as stream stability and the condition of the channel, riprap, slope protection, or stream control devices, including spur dikes. The inspector should be particularly concerned with visible signs of excessive water velocity which may cause undermining of slope protection, erosion of banks, and realignment of the stream. Accumulation of drift and debris on the superstructure and substructure should be noted on the inspection form but not included in the condition rating.

Rate and code the condition in accordance with the previously described general condition ratings and the following descriptive codes:

<u>Code</u>	<u>Description</u>
-------------	--------------------

N	Not applicable. Use when bridge is not over a waterway (channel).
9	There are no noticeable or noteworthy deficiencies which affect the condition of the channel.
8	Banks are protected or well vegetated. River control devices such as spur dikes and embankment protection are not required or are in a stable condition.
7	Bank protection is in need of minor repairs. River control devices and embankment protection have a little minor damage. Banks and/or channel have minor amounts of drift.
6	Bank is beginning to slump. River control devices and embankment protection have widespread minor damage. There is minor streambed movement evident. Debris is restricting the channel slightly.
5	Bank protection is being eroded. River control devices and/or embankment have major damage. Trees and brush restrict the channel.
4	Bank and embankment protection is severely undermined. River control devices have severe damage. Large deposits of debris are in the channel.
3	Bank protection has failed. River control devices have been destroyed. Streambed aggradation, degradation, or lateral movement has changed the channel to now threaten the bridge and/or approach roadway.
2	The channel has changed to the extent the bridge is near a state of collapse.
1	Bridge closed because of channel failure. Corrective action may put bridge back in light service.
0	Bridge closed because of channel failure. Replacement necessary.

Item 62 - Culverts

This item evaluates the alignment, settlement, joints, structural condition, scour,

and other items associated with culverts. The rating code is intended to be an overall condition evaluation of the culvert. Integral wingwalls to the first construction or expansion joint should be included in the evaluation.

Item 58 – Deck, Item 59 – Superstructure, and Item 60 – Substructure should be coded N for all culverts.

Rate and code the culvert condition in accordance with the previously described general condition ratings and the following descriptive codes:

Code Description

- | | |
|---|---|
| N | Not applicable. Use if structure is not a culvert. |
| 9 | No deficiencies. |
| 8 | No noticeable or noteworthy deficiencies which affect the condition of the culvert. Insignificant scrape marks caused by drift. |
| 7 | Shrinkage cracks, light scaling, and insignificant spalling which does not expose reinforcing steel. Insignificant damage caused by drift with no misalignment and not requiring corrective action. Some minor scouring has occurred near curtain walls, wingwalls, or pipes. Metal culverts have a smooth symmetrical curvature with superficial corrosion and no pitting. |
| 6 | Deterioration or initial disintegration, minor chloride contamination, cracking with some leaching, or spalls on concrete or masonry walls and slabs. Local minor scouring at curtain walls, wingwalls, or pipes. Metal culverts have a smooth curvature, non-symmetrical shape, significant corrosion, or moderate pitting. |
| 5 | Moderate to major deterioration or disintegration, extensive cracking and leaching, or spalls on concrete or masonry walls and slabs. Minor settlement or misalignment. Noticeable scouring or erosion at curtain walls, wingwalls, or pipes. Metal culverts have significant distortion and deflection in one section, significant corrosion or deep pitting. |
| 4 | Large spalls, heavy scaling, wide cracks, considerable efflorescence, or opened construction joint permitting loss of backfill. Considerable settlement or misalignment. Considerable scouring or erosion at curtain walls, wingwalls, or pipes. Metal culverts have significant distortion and deflection throughout, extensive corrosion or deep pitting. |
| 3 | Any condition described in Code 4 but which is excessive in scope. Severe movement or differential settlement of the segments, or loss of fill. Holes may exist in walls or slabs. Integral wingwalls nearly severed from culvert. Severe scour or erosion at curtain walls, wingwalls, or pipes. Metal culverts have extreme distortion and deflection in one section, extensive corrosion, or deep pitting with scattered perforations. |
| 2 | Integral wingwalls collapsed, severe settlement of roadway due to loss of fill. Section of culvert may have failed and can no longer support embankment. Complete undermining at curtain walls and pipes. Corrective action required to maintain traffic. Metal culverts have extreme distortion and deflection throughout with extensive perforations due to corrosion. |
| 1 | Bridge closed. Corrective action may put bridge back in light service. |
| 0 | Bridge closed. Replacement necessary. |

Structural capacity is defined as the designed strength of the member. However, structural capacity is different than load-carrying capacity. Load-carrying capacity refers to the ability of the member to carry the legal loads of the highway system of which the bridge is a part. Therefore, a bridge could possibly have good structural capacity yet be load posted because it is unable to carry the legal loads.

A bridge's load-carrying capacity is not to influence condition ratings. The fact that a bridge was designed for less than current legal loads, and may even be posted, should have no influence upon condition ratings.

The load-carrying capacity of a bridge is reflected in the Structural Evaluation appraisal rating. A bridge's structural capacity is reflected in the condition ratings of the bridge components. Component ratings are determined by applying condition descriptions, which are general in nature, covering a broad array of bridge components and material types. The inspector must be familiar with terminology concerning material types and associated deterioration to utilize condition descriptions for accurately assigning condition ratings. The following illustrates several common deterioration terms found in condition descriptions and their associated material types:

- Section loss usually applies to steel members or reinforcing steel
- Fatigue crack applies to steel members
- Cracking/spalling usually are used to describe concrete
- Shear crack usually applies to concrete but may apply to timber as well
- Checks/splits applies to timber members
- Scour can apply to substructure or channels

Establishing a link between material type and deterioration allows for accurate component ratings determined by utilizing condition descriptions for ratings 9 through 1 found in the general condition rating guidelines.

Supplemental rating guidelines, which may be developed by individual states, are intended to be used in addition to the *Coding Guide* to make it easier for the inspector to assign the most appropriate condition rating to the component being considered and improve uniformity.

Using the material and component specific supplemental rating guidelines (found in the 1995 edition of the *Coding Guide*) helps to clarify how each type of defect affects the condition rating. Care must be taken not to "pigeonhole" the rating based on only one word or phrase. The following is one suggested method for determining proper condition ratings:

- Identify phrases that describe the component
- Read through the rating scale until encountering phrases that describe conditions that are more severe than what actually exists
- Be sure to read down the ratings list far enough
- Correct rating number then is one number higher

This procedure should generally work with all of the condition rating guidelines.

**Condition State
Assessment**

A narrative description with quantities is required in the first part of the inspection. Condition state summaries are then developed for the bridge element. The information from the narrative and condition state summaries are then used to complete the element level condition report showing quantities at the correct rating value. Smart Flags are also used to specifically describe deck cracking (top and underside), fatigue cracking, pack rust, settlement, and scour. Refer to Topic 4.5 for a more detailed explanation of the Element Level Bridge Management System.

4.2.3

Appraisal Rating Items

**Appraisal Rating
Guidelines**

The following SI&A items are known as appraisal rating items:

- Item No. 67 – Structural Evaluation
- Item No. 68 – Deck Geometry
- Item No. 69 – Underclearances, Vertical and Horizontal
- Item No. 71 – Waterway Adequacy
- Item No. 72 – Approach Roadway Alignment

Appraisal rating items are used to evaluate a bridge in relation to the level of service it provides on the highway system of which it is a part. The level of service for a bridge describes the function the bridge provides for the highway system carried by the bridge. The structure should be compared to a new one that is built to current standards for that particular class of road. The exception is Item 72, Approach Roadway Alignment. Rather than comparing the alignment to current standards, it is compared to the general existing alignment of the roadway approaches to the bridge compared to the general highway.

The level of service goals used to appraise bridge adequacy vary depending on the highway functional classification, traffic volume, and other factors. The goals are set with the recognition that widely varying traffic needs exist throughout highway systems. Many bridges on local roads can adequately serve traffic needs with lower load capacity and geometric standards than would be necessary for bridges on heavily traveled main highways.

If national uniformity and consistency are to be achieved, similar structure, roadway, and vehicle characteristics must be evaluated using identical standards. Therefore, tables and charts have been developed which must be used to evaluate the appraisal rating items for all bridges submitted to the National Bridge Inventory, regardless of individual State criteria used to evaluate bridges.

The following general appraisal rating guidelines (obtained from the 1995 edition of the *Coding Guide*) are used to evaluate structural evaluation, deck geometry, underclearances, waterway adequacy, and approach roadway alignment.

<u>Code</u>	<u>Description</u>
N	Not applicable
9	Superior to present desirable criteria
8	Equal to present desirable criteria
7	Better than present minimum criteria
6	Equal to present minimum criteria
5	Somewhat better than minimum adequacy to tolerate being left in place as is
4	Meets minimum tolerable limits to be left in place as is
3	Basically intolerable, requiring high priority of corrective action
2	Basically intolerable, requiring high priority of replacement
1	This value of rating code not used
0	Bridge closed

The specific tables for Items 67 through 69, 71 and 72 appear in the *Coding Guide* and are detailed enough that several states now program their computerized bridge management system to automatically calculate several of the appraisal rating items. Thus, some inspectors may not be responsible for coding these items. Inspectors may be asked to field verify the computed appraisal ratings.

Item 67 - Structural Evaluation - The item description and procedures used to determine the Structural Evaluation Appraisal Rating are located in Item 67 of the *Coding Guide*. The correct way to evaluate this item for bridges is to consider the following factors:

- The lowest rating dictated by Item 59 - Superstructure, Item 60 - Substructure or Comparison of Item 29 - ADT and Item 66 - Inventory Rating.
- For culverts, the lower of Item 62 - Culverts or Comparison of Item 29 - ADT and Item 66 - Inventory Rating.

Item 68 - Deck Geometry - The deck geometry appraisal evaluates the curb to curb bridge roadway width and the minimum vertical clearance over the bridge roadway. This item is coded by determining two appraisal ratings, one for bridge roadway width and one for the minimum vertical clearance. The lower of these two is the appraisal rating. The *Coding Guide* includes the following scenarios to choose from for the bridge roadway width appraisal:

- Bridges with two lanes carrying two-way traffic.
- Bridges with one lane carrying two-way traffic.
- All other two-way traffic situations.
- Bridges with one-way traffic.

Item 69 - Underclearances, Vertical and Horizontal - This item refers to the vertical and horizontal underclearances from the through roadway under the structure to the superstructure or substructure units. The item description and coding guidelines, which are located in Item 69 of the *Coding Guide*, are used to determine the Underclearance Appraisal Rating. This item is similar to Item 68 in

that two different ratings are developed: one for vertical underclearance and one for horizontal underclearance. The lower of these two is the appraisal rating.

Item 71 - Waterway Adequacy - Waterway adequacy is appraised with respect to passage of flow through the bridge. The rating is tied to flood frequencies and traffic delays. Appraisal ratings are assigned by the table contained in Item 71 of the *Coding Guide* and are based on the functional classification of the road carried by the structure, hydraulic and traffic data for the structure, and site conditions.

Item 72 - Approach Roadway Alignment – This appraisal is based on comparing the alignment of the bridge approaches to the general highway alignment of the section of roadway on which the structure is located. The rating guidelines are correctly applied by determining if the vertical or horizontal curvature of the bridge approaches differs from the section of highway the bridge is on, resulting in a reduction of vehicle operating speed to cross the bridge. The guidelines for FHWA Item 72, Appraisal or Approach Roadway Alignment, are as follows:

- If no reduction in the operating speed of a vehicle is required compared to the highway, code Item 72 as an “8.”
- If only a very minor reduction in the operating speed of a vehicle is required compared to the highway, code Item 72 as a “6.”
- If a substantial reduction in the operating speed of a vehicle is required compared to the highway, code Item 72 as a “3.”

The following guidelines indicate a means of determining the difference between a minor reduction and substantial reduction of operating speed:

- Minor reduction in operating speed - ≤ 9 mph
- Substantial reduction in operating speed - ≥ 10 mph

The remaining codes between these general values should be applied at the inspector’s discretion.

A narrow bridge does not affect the Approach Roadway Alignment Appraisal. The narrow bridge would be accounted for in Item 68, Deck Geometry.

Items affecting sight distance at the bridge, unrelated to vertical and horizontal curvature of the roadway, such as vegetation growth and substructure units of overpass structures do not affect the Approach Roadway Alignment Appraisal.

Item 36 - Traffic Safety Features - For structures on the National Highway System (NHS), this appraisal is based on comparing the traffic safety features in place at the bridge site to current national standards set by regulation, so that an evaluation of their adequacy can be made. For structures not on the National Highway System (NHS), the procedure is the same, however, it shall be the responsibility of the highway agency (state, county, local, or federal) to set standards. The item description and procedures used to determine the Traffic Safety Feature Appraisal Rating are located in Item 36 of the *Coding Guide*. The following are the traffic safety features to be coded:

- Bridge Railings

- Transitions
- Approach Guiderail
- Approach Guiderail Ends

Item 113 - Scour Critical Bridges – This item is used to identify the current status of the bridge regarding its vulnerability to scour. A scour critical bridge is one with abutment or pier foundations that are rated as unstable due to observed scour at the bridge site, or a scour potential as determined from a scour evaluation study including a scour analysis made by hydraulic, geotechnical, or structural engineers. The item description, procedures, and code descriptions are located in Item 113 of the *Coding Guide*.

4.2.4

Maintenance Rating Guidelines

It is usually necessary to evaluate the condition of more items than those rated on the SI&A forms, because the SI&A condition items cover such broad components. For example, SI&A Item 62 covers all structural components of a culvert. Additionally, the SI&A numerical rating system is not well suited for evaluating minor items. Minor items are essentially limited to ratings of “N”, “9”, “8”, or “7” since the other rating numbers imply a significant impact on the overall integrity or safety of the structure. Therefore, a modified rating system should be used for rating the condition of items added to supplement the SI&A items. Since items are added primarily to identify potential maintenance problems, the modified rating scale should be oriented toward maintenance.

A sample maintenance rating system is shown in Table 4.2.1. The rating system shown provides a numerical scale that is related to the urgency of maintenance action required, as well as the action which should be taken by the inspector.

It is important to note that the inspector basically has three courses of action, depending on the severity of conditions found. Each of these actions involves noting the condition of the components in the inspection report. When no immediate maintenance actions are required, the note in the report is all that is necessary. When a high priority should be assigned for correcting problems found during the inspection, some type of special notification to maintenance personnel is recommended. When immediate action is required to address a hazardous situation or preserve the integrity of the structure, maintenance personnel should be notified on an emergency basis.

Care must be exercised when using different rating systems, particularly when combining the ratings given to supplemental items to arrive at ratings for SI&A items. SI&A item ratings usually represent a composite rating of a group or broad category of supplemental items. The SI&A ratings should not merely be an average of the ratings assigned to the supplemental items but should be based on the inspector’s judgement. A low rating in one supplemental item will usually control the composite rating.

Maintenance Urgency Index	Maintenance Immediacy of Action	Inspection Course of Action
9	No repairs needed.	Note in inspection report only.
8	No repairs needed. List specific items for special inspection during next regular inspection.	
7	No immediate plans for repair. Examine possibility of increased level of inspection.	
6	Repair by end of next season – add to scheduled work.	Special notification to superior is warranted.
5	Place in current schedule – current season, first reasonable opportunity.	
4	Priority – current season, review work plan for relative priority, adjust schedule if possible.	
3	High priority – current season, as soon as can be scheduled.	Verbally notify superiors immediately and confirm in writing.
2	Highest priority – discontinue other work if required, emergency basis or emergency subsidiary actions if needed (post, one-lane traffic, no trucks, reduced speed, etc.).	
1	Emergency actions required – reroute traffic and close.	
0	Facility is closed for repairs.	

Table 4.2.1 Maintenance Rating Scale

4.2.5

Overall Culvert Ratings

General

Topics 7.12, 12.3, and 12.4 address the individual components of various culverts. Overall ratings consider all of the components which make up a culvert and are useful in establishing maintenance, rehabilitation, and replacement programs and priorities.

Some of a culvert's individual components are not rated in the SI&A sheet. However, they are useful supplemental items in defining the condition and in determining the overall ratings. The SI&A sheet has several items that require evaluation of the culvert as a whole. The SI&A items can be divided into three categories: overall condition, load-carrying capacity, and remaining life.

Overall Condition

Two items on the SI&A sheet pertain to the overall condition of culverts. Item 62, Culverts, covers the condition of the culvert's structural and hydraulic components (alignment, settlement, culvert barrel, end treatment, and embankment). Item 67, Structural Evaluation, covers the evaluation of the structural components and the load-carrying capacity.

Overall ratings must not be an average of the ratings assigned to individual components. Very often a low rating for one component will control the overall rating, but when assigning an overall rating, the inspector should consider each component and its possible effect on the culvert. The inspector should consider whether the component is functioning properly, whether it could pose a threat to safety or cause property damage, whether it could cause more extensive damage if not repaired, and whether the repairs represent rehabilitation or maintenance.

Load-carrying Capacity

SI&A Items 64, 66, and 70 are based on the loads which the structure can carry. Item 64, Operating Rating, is the maximum load the structure can carry. Item 66, Inventory Rating, is the load which can be carried repeatedly for an indefinite period of time. Item 70, Bridge Posting, is a rating based on an evaluation of the culvert's load-carrying capacity and the state's legal load limits. The procedures used for determination of these capacity ratings should take into account the condition of the culvert at the time of the inspection.

Remaining Life

The inspector estimates the number of years that remain before major rehabilitation or replacement of the culvert is required. The estimate should be based on the design life of the barrel material, the years of service prior to the inspection, and the condition of the culvert at the time of the inspection. The current condition and the performance of the culvert material under similar conditions are the key considerations. Where durability is a problem, electrical resistivity and pH measurements of the surrounding soil and the stream may be helpful in estimating the remaining life.

4.2.6

Functionally Obsolete and Structurally Deficient

Definitions

A bridge is considered to be functionally obsolete if it has deck geometry, load carrying capacity, clearance or approach roadway alignment that no longer meets the criteria for the system of which the bridge is a part.

One in seven bridges in the United States is functionally obsolete. Functionally obsolete bridges are those that do not have adequate lane widths, shoulder widths, or vertical clearances to serve the traffic demand or those that may be occasionally flooded.

Bridges are considered to be structurally deficient where 1) significant load carrying elements are found to be in poor or worse condition due to deterioration and/or damage or, 2) the adequacy of the waterway opening provided by the bridge is determined to be extremely insufficient to the point of causing intolerable traffic interruptions

Any bridge classified as structurally deficient is excluded from the functionally obsolete category.

General Qualifications

In order to be considered for either the structurally deficient or functionally obsolete classification, a highway bridge must meet the following:

Structurally Deficient -

1. A condition rating of 4 or less for
 - Item 58 - Deck; or
 - Item 59 - Superstructures; or
 - Item 60 - Substructures; or
 - Item 62 - Culvert and Retaining Walls.⁽¹⁾ or
2. An appraisal rating of 2 or less for
 - Item 67 - Structural Evaluation; or
 - Item 71 - Waterway Adequacy.⁽²⁾

Functionally Obsolete -

1. An appraisal rating of 3 or less for
 - Item 68 - Deck Geometry; or
 - Item 69 - Underclearances;⁽³⁾ or
 - Item 72 - Approach Roadway Alignment. or
2. An appraisal rating of 3 for
 - Item 67 - Structural Evaluation; or
 - Item 71 - Waterway Adequacy.⁽²⁾

1. Item 62 applies only if the last digit of Item 43 (Structure Type) is coded 19.
2. Item 71 applies only if the last digit of Item 42 (Type of Service) is coded 0, 5, 6, 7, 8 or 9.
3. Item 69 applies only if the last digit of Item 42 is coded 0, 1, 2, 4, 6, 7 or 8.

4.2.7

Sufficiency Rating

Definition

Sufficiency rating (S.R.) is a calculated numeric value used to indicate the sufficiency of a bridge to remain in service. The rating is calculated using the sufficiency rating formula. Sufficiency rating is discussed in detail in Appendix B of the *Coding Guide*.

Sufficiency Rating Formula

$$S.R. = S_1 + S_2 + S_3 - S_4$$

$$0\% \leq S.R. \leq 100\%$$

(entirely deficient) (entirely sufficient)

where: S_1 = 55% max.; based on structural adequacy and safety (i.e., superstructure or substructure condition and load capacity).

S_2 = 30% max.; deals with serviceability and functional obsolescence (items such as deck condition, clearances, roadway alignment and width, etc.).

S_3 = 15% max.; concerns essentiality for public use (items such as detour length, average daily traffic, and defense highway designation).

S_4 = 13% max.; deals with special reductions based on detour length, traffic safety features, and structure type.

Eighteen SI&A sheet items are used to calculate these four factors which therefore determine the sufficiency rating. Sufficiency rating is not normally calculated manually. Usually, it is included in the agency's inventory computer program and is calculated automatically by the computer based upon the inventory data collected by the bridge inspector.

Uses

Sufficiency Rating (SR) is used by the federal and state agencies to determine the relative sufficiencies of all of the nation's bridges. In the recent past, eligibility for federal funding with Highway Bridge Replacement and Rehabilitation Program funds has been determined by the following criteria:

$$S.R. \leq 80 \quad \text{Eligible for rehabilitation}$$

$$S.R. < 50 \quad \text{Eligible for replacement}$$

Some states use the sufficiency rating as the basis for establishing priority for repair or replacement of bridges; the lower the rating, the higher the priority. Several states are developing specific bridge management procedures with priority guidelines for repair or replacement of bridges. By using these types of procedures, priority ratings can be established by considering the significance or impact of such level-of-service parameters as traffic volume and class of highway.

This page intentionally left blank.

Table of Contents

Section 4 Bridge Inspection Reporting System

4.3	Record Keeping and Documentation	4.3.1
4.3.1	Introduction.....	4.3.1
4.3.2	Methods of Record Keeping	4.3.1
	Traditional	4.3.1
	Electronic Data Collection	4.3.2
4.3.3	General Items in the Bridge Record.....	4.3.3
	Plans	4.3.3
	Specifications	4.3.4
	Correspondence	4.3.4
	Photographs	4.3.4
	Photo Log.....	4.3.4
	Materials and Tests.....	4.3.5
	Maintenance and Repair History	4.3.5
	Coating History	4.3.5
	Accident Records.....	4.3.5
	Posting	4.3.5
	Permit Loads.....	4.3.6
	Flood Data	4.3.6
	Traffic Data	4.3.6
	Inspection History	4.3.7
	Inspection Requirements	4.3.7
	Structure Inventory and Appraisal Sheets	4.3.7
	Inspection Forms.....	4.3.7
	Inventories and Inspections	4.3.19
	Rating Records	4.3.19
	Inspection Notes and Sketches	4.3.19
	Summary of Findings	4.3.23
4.3.4	Documentation	4.3.23
	Element Identification	4.3.23
	Orientation.....	4.3.24
	Element Dimensions.....	4.3.26
	Defect Identification.....	4.3.27
	Defect Qualification	4.3.28
	Defect Quantification	4.3.28
	Defect Location	4.3.29

Abbreviations for Field Inspection Notes

Abut. = Abutment	Hvy. = Heavy
Adj. = Adjacent	Int. = Interior
B. = Bent	Lac. = Lacing
Btw. = Between	Lat. = Lateral
Bot. = Bottom	Lat. Br. = Lateral Brace
B.S. = Both Sides	Lgth. = Length
[= Channel (Steel Shape)	Low. = Lower
cm = Centimeter	Lt. = Light
Col. = Column	M = Meters
Conc. = Concrete	Med. = Medium
Cond. = Condition	Mid. = Middle
Conn. = Connection	N = North
Cr. = Crack	No Vis. Def. = No Visible Defects
Delam. = Delamination, Delaminated	N.S. = Near Side
Deter. = Deterioration	P = Pier
Diag. = Diagonal	Pl. = Plate
Diam. = Diameter	S = South
Diaph. = Diaphragm	S.I.P. = Stay-in-Place Forms
D.S. = Downstream	SF = Square Feet
E = East	Stiff. = Stiffener
Eff. = Efflorescence	Str. = Stringer
Elev. = Elevation	T. Welds = Tack Welds
Exp. = Expansion	Typ. = Typical
F.B. = Floorbeam	U = Upper
F.L. = Full Length	U.S. = Upstream
Flg. = Flange	Vert. = Vertical
F.S. = Far Side	Vis. = Visible
Ft. = Feet	Vis. S. = Visible Signs
Gus. = Gusset	W = West
H.L. = Hairline	W = Wide Flange (Steel Shape)
Horz. = Horizontal	L = Angle (Steel Shape)

Topic 4.3 Record Keeping and Documentation

4.3.1

Introduction

While the inspection of small bridges usually only requires the use of the standard inspection form, the inspection of large or complex bridges requires the use of an inspection notebook, in addition to any standard inspection forms. The inspection notebook should contain:

- A standard notation system for indicating the condition of the elements or members
- Sketches of elements or members showing typical and deteriorated conditions (some of these can be pre-made to allow more expediency during the inspection)
- Standard nomenclature and abbreviations for the elements of members and the components made up of these members
- A log or index for photographs
- Brief narrative descriptions of general and component conditions

When the notebook format is selected for recording bridge inspection results, the information should be recorded systematically. However, many bridge owners differ significantly in their required format. Most of the above information, if not provided on the inspection report, should be available in the bridge record.

4.3.2

Methods of Record Keeping

Traditional

All signs of distress and deterioration should be noted with sufficient precision so that future inspectors can readily make a comparison of conditions. The most commonly used method for record keeping is pencil and paper. The inspector writes findings on forms, sketches, and notebooks (see Figure 4.3.1). This method is extremely flexible in that the inspector can draw whatever configurations are necessary to best describe and document deficiencies.



Figure 4.3.1 Inspector Taking Notes

Electronic Data Collection

Another method of record keeping is electronic data collection (see Figure 4.3.2). This technology provides a significant advantage in a number of areas. With all the bridge data available at the site, the inspector can retrieve and edit previous records. This not only saves time but eliminates the need for reentering data. Also, it eliminates errors that can occur when transferring the inspector's field notes to the computer back at the office. Electronic data collection provides a logical and systematic sequence of inspection, ensuring that no bridge elements are overlooked. It also allows the inspector to compare the current deficiencies with previous reports and note if any deterioration has gotten worse.



Figure 4.3.2 Electronic Data Collection

4.3.3

General Items in the Bridge Record

Bridge records are used to maintain detailed information on each important structure. A thorough study of the available historical information can be extremely valuable in identifying possible critical areas of structural or hydraulic components and features. Because this information may require considerable effort to assemble, a separate file should be established for each structure.

The contents of any particular file may vary depending upon the size and age of the structure, the functional classification of the road carried by the structure, and the informational needs of the agencies responsible for inspection and maintenance. A very small structure may be documented in an inventory listing or with a file that contains little more than an inventory card plus dates and comments of previous inspections. For larger structures, it is recommended that the following types of information be assembled when possible.

According to the *AASHTO Manual for the Condition Evaluation of Bridges*, the bridge record should contain the following information:

- Plans: including construction plans, shop and working drawings, “as-built” drawings, rehabilitation drawings
- Specifications
- Correspondence
- Photographs
- Materials and tests including material certification, material test data, load test data
- Maintenance and repair history
- Coating history
- Accident reports
- Posting
- Permit loads
- Flood data
- Traffic data
- Inspection history
- Inspection requirements
- SI&A sheets
- Inventories and inspections
- Rating records

Plans

“As built” or design plans should be included in a bridge record. If plans are not available, the following types of construction information should be determined: date built; type of structure, including size, shape, and material; design capacity; and design service life. Hydraulic data should also be assembled where available, including structure profile gradeline, elevation of inverts or footings, stream channel and water surface during normal and high flows, design storm frequency, drainage area, design discharge, date of design policy, flow conditions, limits of flood plain, type of energy dissipaters (if present), cut-off wall depth, channel alignment, and channel protection.

Specifications

The bridge record should contain a complete copy of the technical specifications used to design and build the bridge. When a general specification was used, only the special provisions need to be included in the file. The edition and date of the general specifications should be noted in the bridge record.

Correspondence

The bridge record should include any applicable letters, memorandums, and notices of project completion, construction diaries, telephone logs and any other information directly concerning the bridge in chronological order.

Photographs

Photographs are used to supplement the inspection notes and sketches. A minimum of two photographs should be included in the bridge record. A topside view of the bridge roadway and at least one elevation view of the bridge need to be included. Photographs showing major defects, or other features, such as utility attachments or channel alignment, should also be included. Also include photographs that show any load posting signs.

Photo Log

A photo log should also be kept during the inspection. The photo log should include the date, roll or disk number, photo number, and description of each photograph. It is best to be very specific when describing the photos (see Figure 4.3.3). Descriptions should include both the location of the member and a brief description of any deficiencies.

Baker
 MICHAEL BAKER, JR., INC.
 Atside Business Park
 160 Atside Drive
 Moon Township, PA 15108

PHOTO LOG FORM
 INSPECTORS LAA ROLL NO. 1
 BRIDGE NO. _____ DATE: 10/1/04
 BRIDGE NAME: FRISHKORN RD
North Fayette Twp. Bridges Flood Inspection

MIN. PHOTOS REQUIRED
 A. General Elevation View B. Near Approach C. Far Approach
 D. Upstream E. Down Stream F. General Underside View
 G. Typical Abutment H. Typical Pier
 Note: Insert appropriate letter when applicable.

PHOTO #	LOCATION	DESCRIPTION
2	NEAR APPR TOWARD BRIDGE	
3	" " FROM "	
4	FAR " " "	
5	" " TOWARD "	
6	DOWNSTREAM ELEVATION	
7	UPSTREAM "	
8	NEAR ABUTMENT	BLURRY
9	FAR ABUT AT US WW CORNER	
10	FAR ABUT FROM DS END	
11	NR CORNER & WW	
12	DS FASCIA BM TOWARD NEAR ABUT	
13	DS " " FAR "	
14	DS CHANNEL ALIGNMENT	
15	US " "	
16	US FASCIA BM TOWARD NEAR ABUT	
17	UNDERMINING AT FAR ABUT & US WW CORNER UP TO 2'-6" DP	
18	" " "	
19	SHLDR AT FL CORNER	DIRT SHLDR WAS REMOVED TO EXPOSE THE BACK OF THE FAR ABUT. THE TOP OF THE ABUT HERE MEASURED 14" THK.
20	" "	" "
21	" "	" "
22	NR CORNER	WASHED OUT FROM RDWY DRAINAGE
23	" "	" "

Figure 4.3.3 Sample Photo Log

Materials and Tests

Certificates for type, grade and quality of materials used in construction of the bridge should be included in the bridge record. Examples include steel mill certificates, concrete delivery slips, and any other manufacturer’s certificates. The certificates should be retained in accordance with Bridge Owner policy and statute of limitations.

Reports for any non-destructive or laboratory testing either during or after construction should be included. If any field load testing is performed, reports should also be included in the bridge record.

Maintenance and Repair History

Information about repairs and rehabilitation activities should be collected. This chronological record should include details such as the date, project description, contractor, cost, contract number and any other related data. The types and amount of repairs performed at a bridge or culvert site can be extremely important. Frequent roadway patching due to recurring settlement over a culvert or approach roadway for a bridge may indicate serious problems that are not readily apparent through a visual inspection of the structure itself.

Coating History

This information in the bridge record should document the surface protective coatings used including surface preparation, application method, dry film paint thickness, and types of paint, concrete and timber sealants, and other protective membranes.

Accident Records

Include details of accidents or damage to the bridge in the bridge record (see Figure 4.3.4). This information should include the date of the occurrence, description of the accident, member damage and repairs, and any investigative reports.



Figure 4.3.4 Accident Involving Construction Equipment and a Bridge

Posting

Each bridge record should include load capacity calculations and any required posting arising from the load ratings. The summary of posting actions should include the date of posting and a description of the signing used (see Figure 4.3.5).



Figure 4.3.5 Posted Bridge

Permit Loads

A record of the most significant single-trip permit loads using the bridge should be included in the bridge record. This information is to include any applicable documentation and computations.

Flood Data

A chronological history of major flooding events should be included for bridges over water (see Figure 4.3.6). This history should include high water marks at the bridge site and scour activity.



Figure 4.3.6 Flood Event

Traffic Data

When available, the bridge record should contain a history of the variations in Average Daily Traffic (ADT) and Average Daily Truck Traffic (ADTT) including the frequency and types of vehicles using the bridge. ADT and ADTT are

important factors in determining fatigue life and should be monitored for each bridge and each traffic lane on the bridge. If available, weights of the vehicles using the bridge should also be included in the bridge record.

Inspection History

Data from previous inspections can be particularly useful in identifying specific locations that require special attention during an inspection. Information from earlier inspections can be compared against current conditions to estimate rates of deterioration and to help judge the seriousness of the problems detected and the anticipated remaining life of the structure.

This chronological record of inspections performed on the bridge should include the date and type of inspection. The initial inspection report should be part of the bridge record. Scour evaluations, earthquake data, fracture critical information, deck evaluations, and corrosion studies should also be included when available.

Inspection Requirements

A list of specialized tools and equipment, descriptions of unique bridge details or features needing non-routine inspection procedures, and access requirements should be noted to help in planning the bridge inspection. Any special requirements to ensure inspector and public safety, including a traffic management plan, should also be included as part of the bridge record.

Structure Inventory and Appraisal Sheets

A chronological record of SI&A forms used by the Bridge Owner should be included in the bridge record. Refer to Topic 4.1 for a complete description of SI&A sample forms.

Inspection Forms

Many bridge owners have standard inspection forms. These forms are used for each bridge in their system and give the inspector a checklist of items that are to be reviewed. Another benefit of standardized forms is that it organizes all bridge reports into a consistent format (see Figures 4.3.7 and 4.3.8).

SECTION 4: Bridge Inspection Reporting System
 TOPIC 4.3: Record Keeping and Documentation

PDT Form D-450A (DEC 1996) **Site Data** **BRIDGE MANAGEMENT SYSTEM** **BRIDGE INSPECTION REPORT** BMS Updated b _____ Date _____

A01 _____ **C05** Structure Type (Dept.) _____
 Main _____
 Over _____ Approach _____

Inspection Date **E06** _____ Name of Consultant and/or Inspectors **E12** _____

Inspection Type **E07** _____ Inspected by **E08** _____ Hired by **E13** _____
 Time started _____ Weather Conditions: _____ Temp: _____
 Time completed _____

City Borough Township

Bridge Signing Verification **SIGNING IN FIELD** **Optional Reminder:** Check boxes if Maintenance Activities are needed -->

BMS Item	Type of Sign	Required Sign	Near Advance	Bridge Site		Far Advance	Comments
				Near	Far		
D15	Bridge Weight Limit	T					
D15	Except Combination	T					
D14	One Truck at a Time	Yes / No					
B22/B23	Vert. Clearance - On						See Sketch
B22/B23	Vert. Clearance - Und						See Sketch
	One Lane Bridge	Yes / No	(Opt)			(Opt)	
	Narrow Bridge	Yes / No	(Opt)			(Opt)	
	Hazard Clearance	Yes / No					
	Other						
(Opt)	Other						

Key --> OK: Signs properly installed M: Signs missing D: Signs damaged / incorrect New Wearing Surface Under Bridge: YES NO

Notes

Vert. Clear. Sign **On Feature:** **B01** = **B31** = **Under Feature:** **B01** = **B31** =

E26 Underclearance Appraisal Controlling: Lateral _____ Vertical _____

E28-A Traffic Safety Features (Subfields shown vertically) Posted Speed Limit _____ mph

Bridge Railing _____

Transition _____

Approach Guiderail _____

Approach Rail Ends _____

E28 Approach Alignment _____

E15 Approach Roadway _____

Pavement _____
 Drainage _____
 Shoulders _____

E14 Approach Slab _____

Bump at Bridge Yes No _____

C19 Relief Joint _____

SITE DATA Sheet _____ of _____

Figure 4.3.7 Example Inspection Form – PADOT Form D-450

SECTION 4: Bridge Inspection Reporting System
 TOPIC 4.3: Record Keeping and Documentation

Michigan Department of Transportation **BRIDGE INSPECTION REPORT** 03032-B03

Bridge Number	Inspector Name	Insp Key <input type="checkbox"/>	Pontis ID
Facility Carried			Region
Feature Intersected			Inspection Date Old <input type="checkbox"/> New <input type="checkbox"/>
Location			

PONTIS BRIDGE INSPECTION **English Units**

Element Number	Element Name	Total Quant	State 1		State 2		State 3		State 4		State 5	
			Old	New	Old	New	Old	New	Old	New	Old	New

CREW RECOMMENDATIONS	CONTRACT RECOMMENDATIONS
Deck Patching	Bridge Replacement
Approach Pavement	Superstructure Replacement
Joint Repair	Deck Replacement
Railing Repair	Overlay
Detailed Insp	Widen
Zone Paint	Paint
Substr. Repair	Zone Paint
Slope Repair	Pin and Hanger
Brush Cut	Substructure Repair
Other Crew Work	Other Contract Work

Note: This form is for use on site only, not to be submitted

Figure 4.3.8 Core Element Example Inspection Form – Michigan Department of Transportation

Inventories and Inspections

Inspection reports are included as part of the bridge record. This information should include the results of all inventories and bridge inspections such as construction and repair inspections.

Rating Records

A complete record of the determination of the bridge's load-carrying capacity should also be included in the bridge record. This information will include the design load to indicate the live load the bridge was designed for, the analysis methods used to determine the inventory and operating ratings, and the inventory and operating ratings for the bridge.

If the maximum legal load permitted in the state exceeds the load permitted under the operating rating, then the bridge must be posted according to NBIS. The actual operational status of the bridge must also be indicated in the bridge record.

Inspection Notes and Sketches

In most cases, it will be possible to insert reproductions of portions of the plans in the inspection notes. However, in some instances, sketches will have to be drawn. The inspector may be able to pre-draw the sketches in the office and fill them out in the field (see Figures 4.3.9 through 4.3.11).

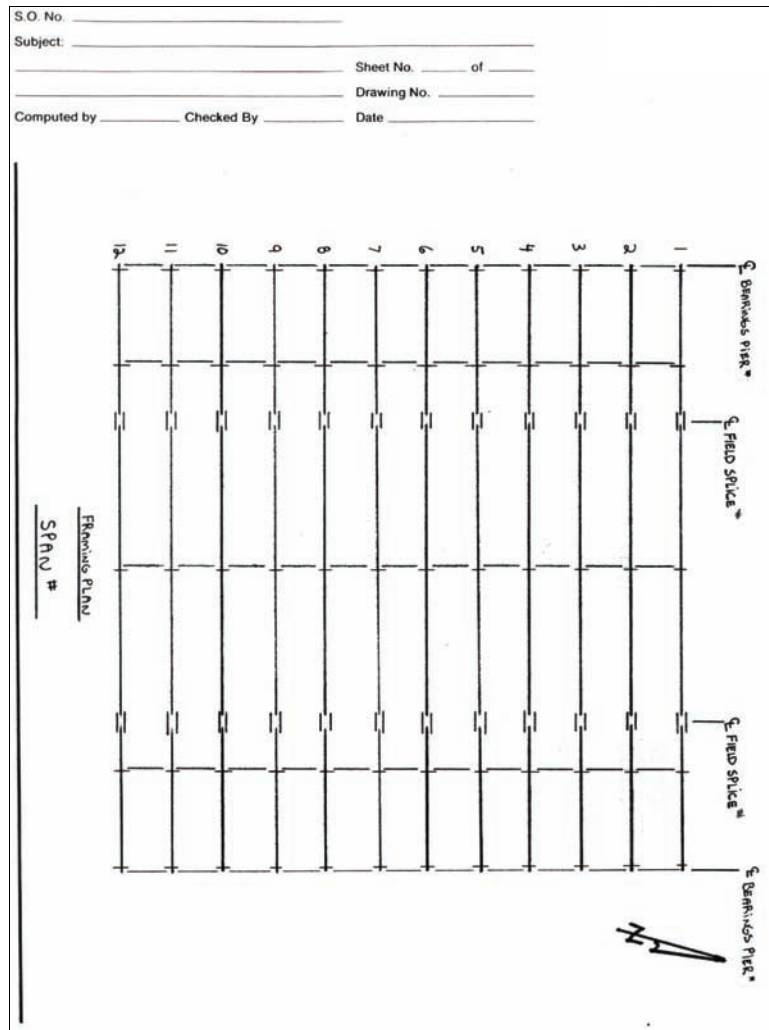

Figure 4.3.9 Framing Plan

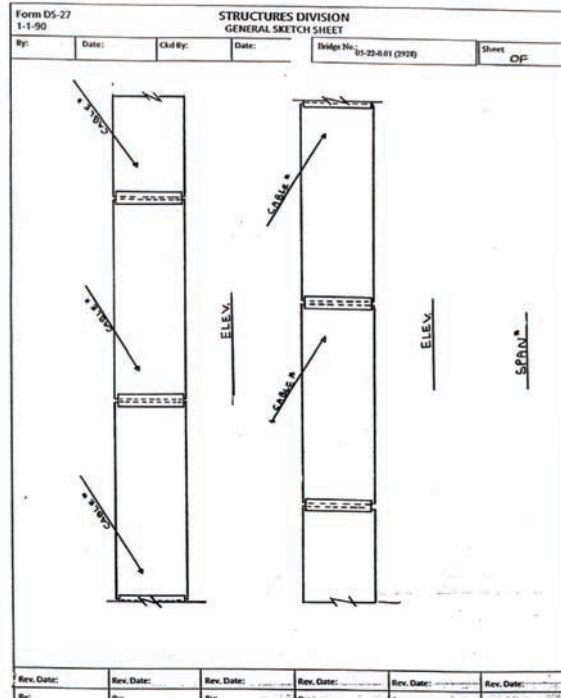

Figure 4.3.10 Girder Elevation

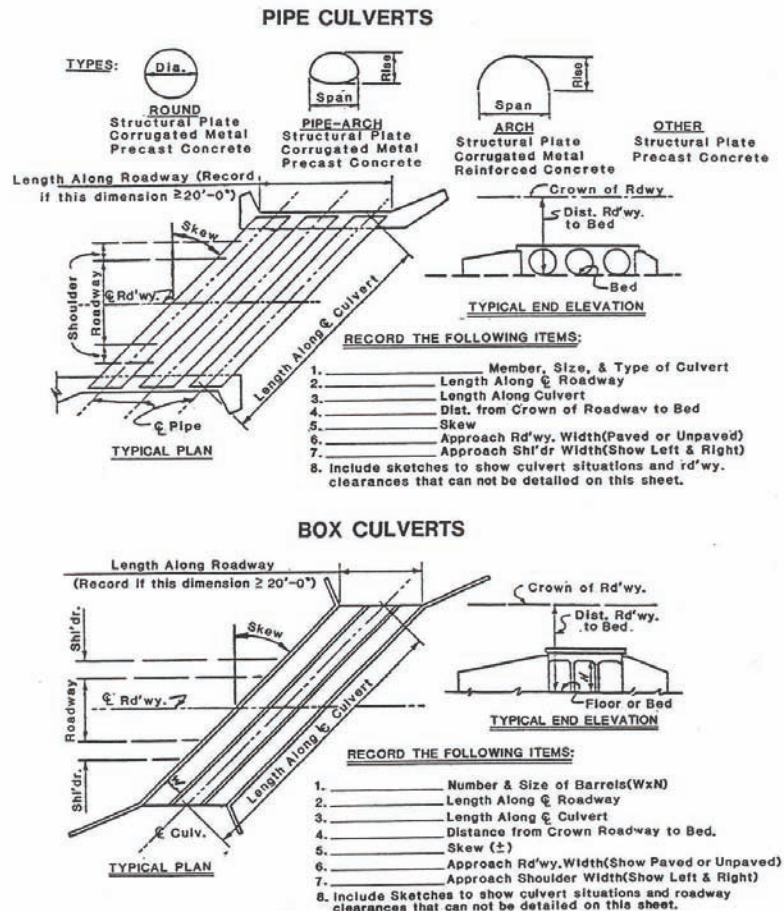

Figure 4.3.11 Typical Prepared Culvert Sketches

The first sketch in the field inspection notes should schematically portray the general layout of the bridge and site information, illustrating the structure plan and elevation data (see Figures 4.3.12 and 4.3.13). The immediate area, the stream or terrain obstacle layout, major utilities, and any other pertinent details should also be included.

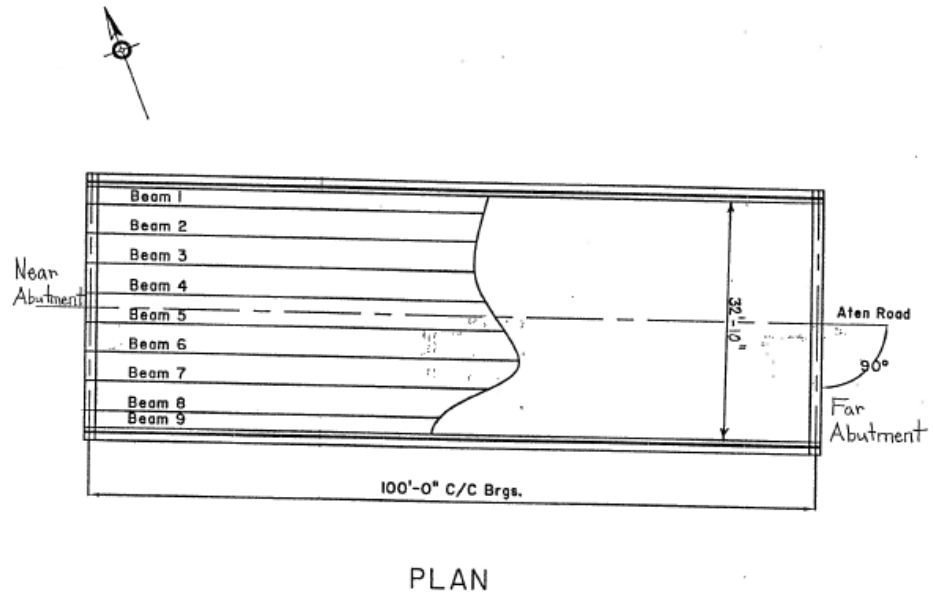

Figure 4.3.12 Sample General Plan Sketch

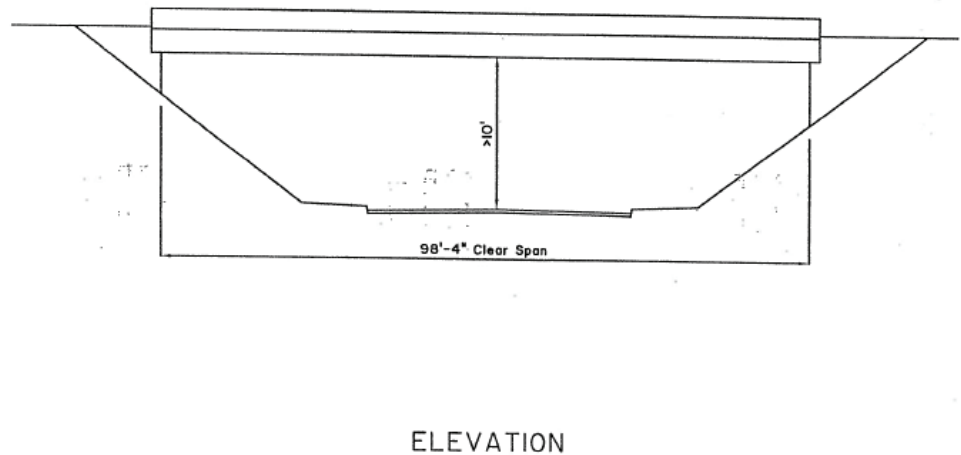

Figure 4.3.13 Sample General Elevation Sketch

Deck sketches should include the condition of deck and haunch, expansion joints, construction joints, curbs, sidewalks, parapets, and railings (see Figure 4.3.14).

SECTION 4: Bridge Inspection Reporting System
 TOPIC 4.3: Record Keeping and Documentation

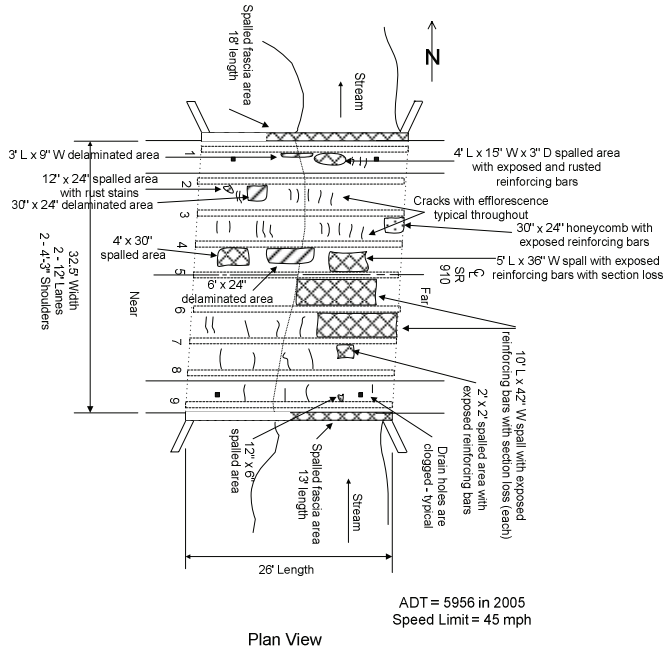

Figure 4.3.14 Sample Deck Inspection Notes

Superstructure units should be sketched in cross section, plan, and elevation views. Items to be inspected include bearings, main supporting members, floorbeams, stringers, bracing, and diaphragms (see Figure 4.3.15).

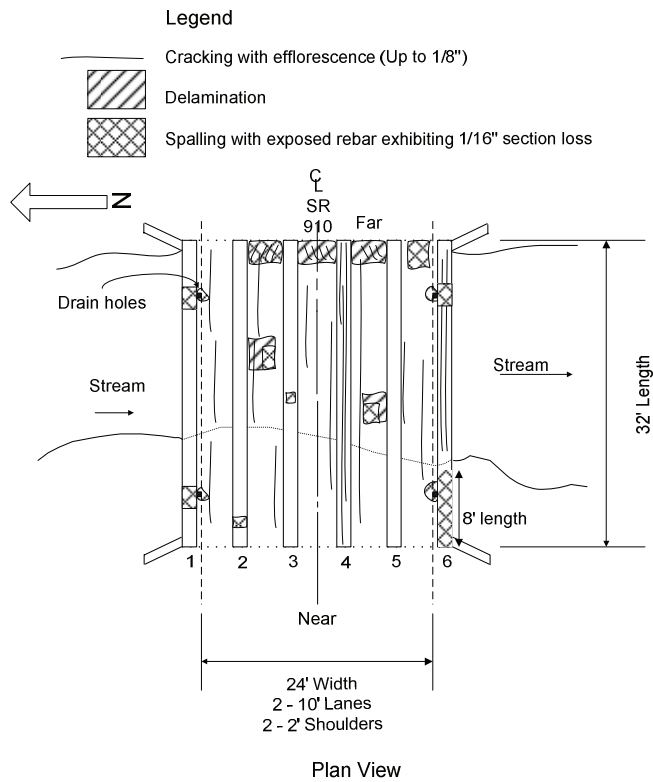

Figure 4.3.15 Sample Superstructure Inspection Notes

Sketches or drawings to describe the condition of each substructure unit should be included (see Figure 4.3.16). In many cases, it is sufficient to draw typical units that identify the principal elements and defects of the substructure. Each of the elements of a substructure unit should be identified so that they can be cross referenced to notes or sketches. Items to be identified include piling, footings, vertical supports, lateral bracing of members, and caps.

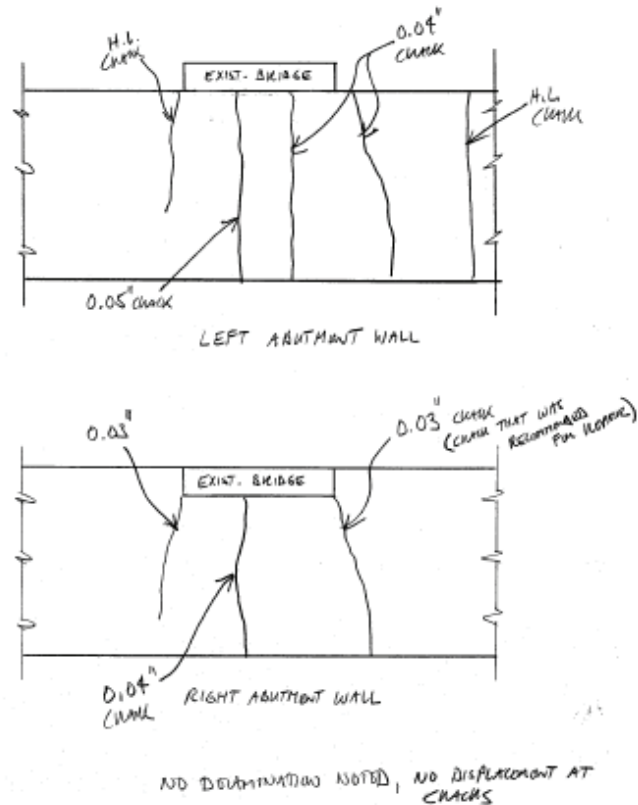

Figure 4.3.16 Sample Substructure Inspection Notes

Summary of Findings

All deficiencies should be reported, no matter how minor they may seem. The inspector should be as descriptive as necessary to report not only the severity of the defect but the location as well. This will be described in further detail later in this topic. When reporting defects, be objective and do not use terms such as “Dangerous” or “Hazardous”.

4.3.4
Documentation

Element Identification

Elements should be identified by the type of material, construction method, and by the function that each element performs.

Some material types and construction methods employed include:

- Timber
 - Solid sawn
 - Laminated: glue-lam or stress laminated
- Concrete

Cast-in-place

Precast: regular reinforcement or prestressed

- Steel
 - Rolled
 - Fabricated: welded or riveted or bolted

Some examples of element functions and the abbreviations used with them are:

- Multi-beam (B1 – B6)
- Deck or slab
- Stringer (S1 – S4)
- Floorbeam (FB0 – FB15)
- Girder (G1, G2)
- Truss chord (U0U1 – U.S.)
- Truss diagonal (U0L2 – D.S.)
- Secondary bracing (Top Lat. Br. U0 U.S. to U1 D.S.)
- Arch
- Spandrel column (Col. 1 – Col. 14 – U.S.)
- Spandrel wall (U.S., D.S. or N, S, E, W)
- Abutment (Abut. 1, Abut. 2)
- Pier (P1 – P4)

Verify any element descriptions or abbreviations are consistent with bridge owner typical nomenclature.

Orientation

Structure orientation is normally established according to highway direction of inventory, mile markers, or stationing. It is important that the orientation of each element be clearly established. The following are some examples:

- Number the substructure units (e.g., Abutment 1 and Pier 3)
- Identify ends of floorbeams with left/right (e.g., north/south or east/west) designations.
- Sides of members can be identified by direction (e.g., “south side of Floorbeam 2” or “northeast elevation of Beam 4”).
- Span numbers and bay numbers should be used to identify general areas on the bridge (see Figure 4.3.17).
- Individual beams or stringers should be numbered left to right, looking in the direction of inventory (see Figure 4.3.18).
- Upstream or downstream designations can be assigned to structures over waterways (e.g., “upstream truss”, “downstream girder”, or “upstream arch”) (see Figure 4.3.19).
- For truss elements, identify the member with joint designations and specify if it is an upstream/downstream or north/south truss (see Figure 4.3.20). Number floorbeams in accordance with the panel point numbers.

If the orientation used during the inspection differs in any way with that used in existing documents, these differences should be clearly stated in the inspection notes.

ELEVATION VIEW

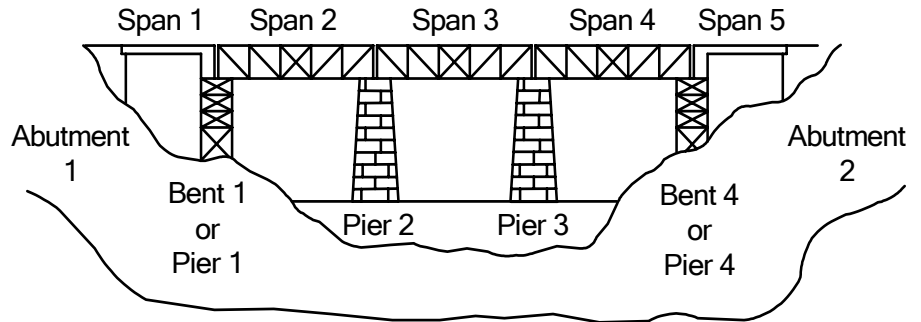

Figure 4.3.17 Sample Span Numbering Scheme

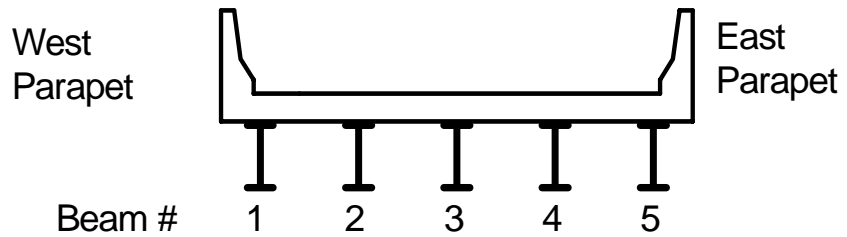
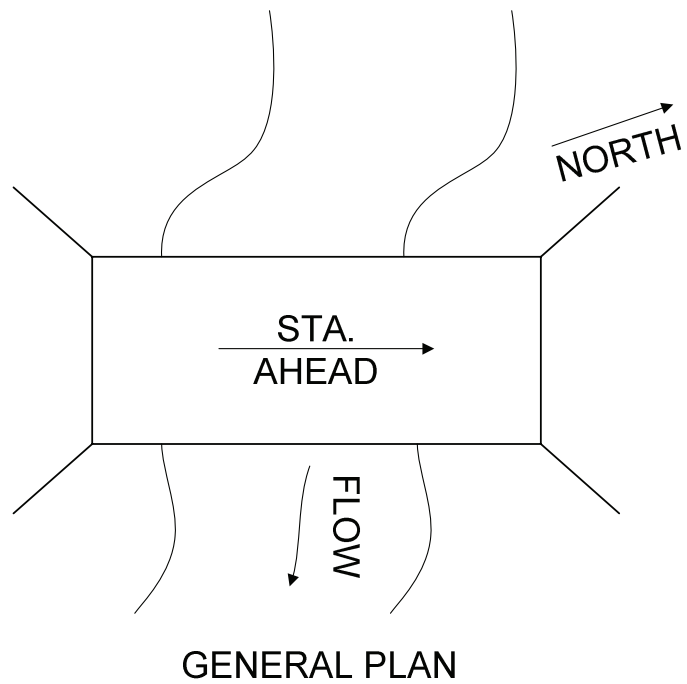

Figure 4.3.18 Sample Typical Section Numbering Scheme



GENERAL PLAN

Figure 4.3.19 Sample Structure Orientation Sketch

ELEVATION VIEW

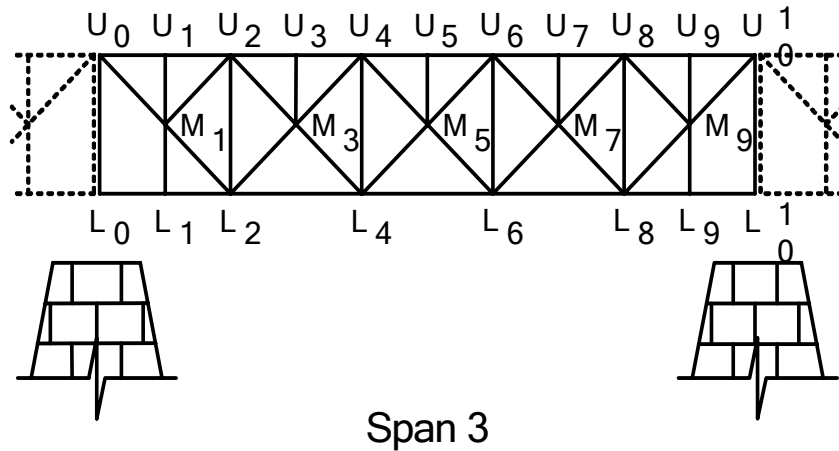

Figure 4.3.20 Sample Truss Numbering Scheme

Element Dimensions

Sufficient dimensions must be documented to establish the cross section and other pertinent dimensions of elements. These should include:

- Deck elements: length, width, and thickness
- Superstructure elements (beam, girder, floorbeam, stringer, and truss member): length, depth, width, flanges and webs (see Figures 4.3.21 and 4.3.22)
- Substructure elements (abutment, columns and caps): width and depth (for rectangular shapes), diameter (for round columns), length, spacing, and pile batter and spacing (for pile bents)

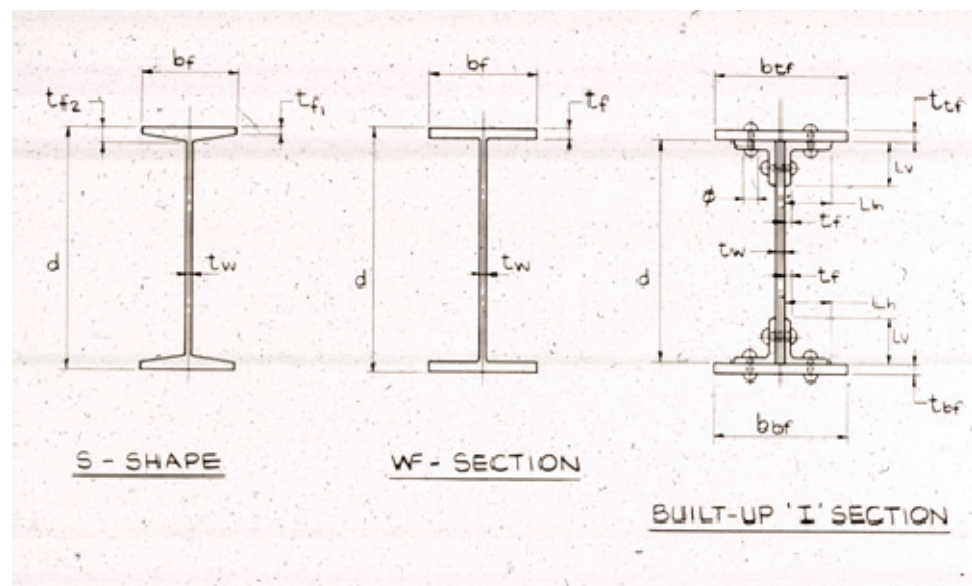

Figure 4.3.21 Steel Superstructure Dimensions

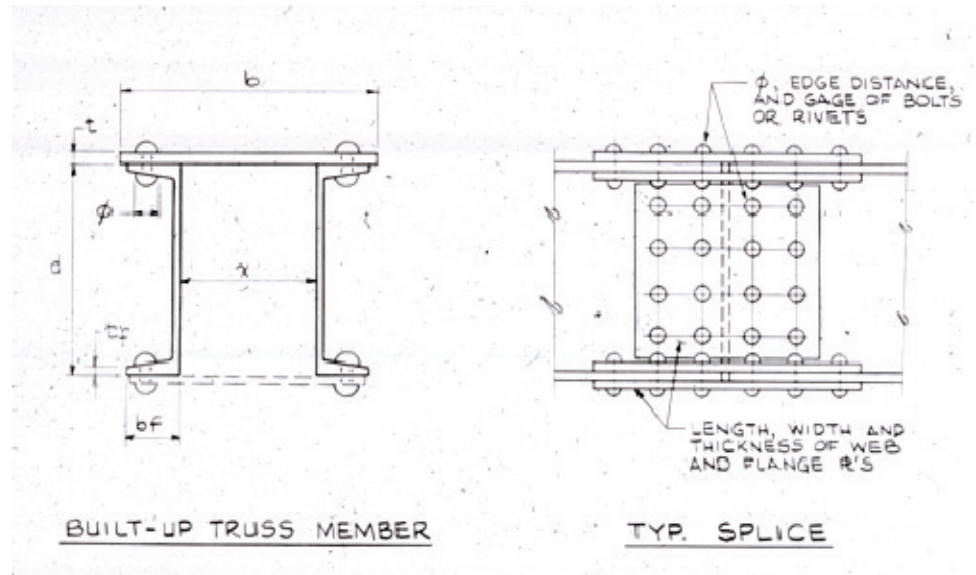

Figure 4.3.22 Truss Member and Field Splice Dimensions

Defect Identification

Material defects should be identified. See Topic 2.1 – Timber, Topic 2.2 – Concrete, Topic 2.3 – Steel, Topic 2.4 – Masonry for detailed descriptions of material defects.

Defects that are likely to occur in timber elements include:

- Natural defects
- Fungi
- Insects
- Marine borers
- Chemical attack
- Delaminations
- Loose connections
- Surface depressions
- Fire
- Impact or collision
- Weathering
- Protective coating
- Failure

Typical concrete defects to look for include:

- Structural cracks
- Non-structural cracks
- Scaling
- Delamination
- Spalling
- Chloride contamination

- Efflorescence
- Ettringite formation
- Honeycombs
- Pop-outs
- Wear
- Collision damage
- Abrasion
- Overload damage
- Reinforcing steel corrosion
- Prestressed concrete deterioration

Some of the defects that may be encountered on steel and iron elements include:

- Corrosion
- Fatigue cracking
- Overloads
- Collision damage
- Heat damage
- Paint failures

Some of the defects that may be encountered on masonry elements include:

- Weathering
- Spalling
- Splitting
- Fire
- Chemicals
- Volume changes
- Frost and freezing
- Abrasion
- Plant growth
- Marine growth

Defect Qualification

Documenting of defects by the inspector must describe the seriousness of a defect. For example:

- Crack sizes – record lengths, widths, and depth
- Section loss – record the remaining section dimensions (when reporting section loss, it is important to document the section remaining rather than trying to estimate the percentage of section loss)
- Deformation – record amount of misalignment

Defect Quantification

The inspector must also describe the quantity of a defect. For example:

- Spalling – 610 mm (2') x 915 mm (3') x 50 mm (2") deep
- Scaling – 1220 mm (4') high by full abutment width

- Delamination – 305 mm (1') x 150 mm (6")
- Decay – 610 mm (2') x 610 mm (2') x 75 mm (3") deep

Defect Location

The exact position of the defect on the element or member is required if load capacity analysis is to be performed. For example:

- Left side of web, top half, 3 feet from north bearing
- Top of top flange, from 3 feet to 6 feet west of Pier 2

The accuracy of the load capacity analysis depends on precise location information for defects:

- Bending moment – Maximum positive moment occurs at or near midspan. Maximum negative moment occurs at the intermediate supports if the structure is continuous.
- Shear/bearing – Shear is maximum at or near the supports. Bearing is maximum at the supports.
- Axial compression members – The capacity of the member to resist compressive forces is reduced by any deformation or change in cross section. The potential capacity reduction is not dependent on where on the member the defect is located. All segments are critical.
- Axial tension members – These members experience a reduction in capacity through loss of section or from cracking. As with the axial compressive members, tensile members are equally susceptible regardless of the location of the defect.
- Combinations – While axial members are critical at all locations, it is not always apparent which members are loaded only in an axial direction. In fact, due to the dead load of the member itself, most are not. Other factors can also contribute to bending forces that will create varying moments, shears, compression, and tension areas within a member that is primarily axial. Because of this, inspectors should identify the exact position of defects in all members using reference points, regardless of the forces acting on the member.

Locating a defect may include tying it to an established permanent reference. Avoid using references that can change over time.

Some examples of proper referencing include:

- 2210 mm (7'-3") from fixed bearing on Beam 3 at Abutment 1
- 940 mm (3'-1") from west corner of Abutment 2
- 760 mm (2'-6") below bridge seat on south face of Column 1, Pier 2

Reference points to avoid:

- Expansion rocker faces
- Ground levels, especially those that may be exposed to water
- Water levels

This page intentionally left blank

Table of Contents

Section 4	
Bridge Inspection Reporting System		
4.4	The Inspection Report.....	4.4.1
4.4.1	Introduction.....	4.4.1
4.4.2	Basic Components of a Comprehensive Bridge Inspection Report	4.4.1
	Table of Contents	4.4.1
	Location Map	4.4.1
	Bridge Description and History.....	4.4.1
	Design Data.....	4.4.1
	Construction Data	4.4.2
	Service Data.....	4.4.2
	Executive Summary.....	4.4.2
	Inspection Procedures.....	4.4.2
	Inspection Results.....	4.4.3
	Load Rating Summary.....	4.4.3
	Conclusions and Recommendations.....	4.4.4
	Report Appendices	4.4.5
	Photographs.....	4.4.5
	Drawings and Sketches	4.4.5
	Inspection Forms.....	4.4.6
	Load Capacity Analysis	4.4.6
	Field Inspection Notes	4.4.6
	Underwater Inspection Report	4.4.6
	Material Testing Results	4.4.6
4.4.3	Importance of the Inspection Report.....	4.4.6
	Source of Information.....	4.4.6
	Legal Document	4.4.7
	Critical Areas.....	4.4.7
	Maintenance	4.4.7
	Load Rating Analysis	4.4.7
	Bridge Management	4.4.7

4.4.4 Quality 4.4.7

Topic 4.4 The Inspection Report

4.4.1

Introduction

The purpose of the bridge inspection reporting system is to have trained and experienced personnel record objective observations of all elements of a bridge and to make logical deductions and conclusions from their observations.

The bridge inspection report should represent a systematic inventory of the current or existing condition of all bridge members and their possible future weaknesses. Moreover, bridge reports form the basis of quantifying the manpower, equipment, materials, and funds that are necessary to maintain the integrity of the structure.

A bridge inspection is not complete until an inspection report is finalized. The bridge inspection report must document all signs of distress and deterioration with sufficient precision so that future inspectors can readily make a comparison of condition. Bridge owners normally set the format to be used when preparing a bridge inspection report. A complete inspection report contains several parts, as outlined in this topic. A sample bridge inspection report is presented in Appendix A. An inspection report should be prepared for special inspections, which are conducted for checking a specific item where a problem or change may be anticipated. Even if no changes are evident, a report should be made for each type of bridge inspection. Some bridge owners also request a special bridge inspection and report when planning a major rehabilitation.

4.4.2

Basic Components of a Comprehensive Bridge Inspection Report

Table of Contents

The table of contents should present the general headings and topics of the inspection report in an orderly manner so that individual sections of the report can be found with ease. It generally follows the title page, and individual sections are listed with their corresponding starting page number.

Location Map

A map should be included with a scale large enough to positively locate the structure. The bridge should be clearly marked and labeled, and the map should have a north arrow.

Bridge Description and History

The bridge description and history section of the report should contain all pertinent data concerning the design, construction, and use of the bridge. The type of superstructure will generally be given first, followed by the type of abutments and piers or bents, along with their foundations. If data is available, indicate the type of foundation soil, maximum bearing pressures, and pile capacities. The type of deck is also indicated.

Design Data

The design information should include a description of the following:

- | | |
|--------------------------------|----------------------------------|
| ➤ Skew angle | ➤ Railing and median |
| ➤ Number and length of spans | ➤ Year constructed/reconstructed |
| ➤ Span type and material | ➤ Number of traffic lanes |
| ➤ Total length | ➤ Design live loading |
| ➤ Bridge width | ➤ Waterway |
| ➤ Deck structure type | ➤ Other features intersected |
| ➤ Wearing surface | ➤ Clearances |
| ➤ Deck protection and membrane | ➤ Encroachments |
| ➤ Sidewalks | ➤ Alignment |

Construction Data

The construction history of the bridge should include the date it was originally built, as well as the dates and descriptions of any repairs or reconstruction projects. State what plans are available, where they are filed, and whether they are “design”, “as-built”, or “rehabilitation”.

Service Data

State the average daily traffic (ADT) count and the average daily truck traffic (ADTT) count, along with the date of record. This information should be updated approximately every five years. Any environmental conditions which may have an effect on the bridge, such as salt spray, industrial gases, bird droppings, and ship and railroad traffic, should be noted in the report.

The history of the bridge is from a structural standpoint and should be developed from information obtained from design, construction and rehabilitation plans, previous inspection reports, maintenance records, discussions with maintenance crews and local residents, and any other available source that offers pertinent information. Items to be included in the history narrative include:

- Year built
- Reconstruction year, if any
- Historical flood frequencies and high water marks
- Maintenance measures and repairs
- Chronological record of conditions
- Reference drawings
- Photos

Executive Summary

The executive summary is a narrative presentation summarizing the inspection and analysis findings in regard to the qualitative condition and the load capacity of the bridge, along with an overview of recommendations. The executive summary must properly identify the bridge (e.g., name, number, and location) and the date of inspection. The executive summary should also present any high priority repair items.

Inspection Procedures

The procedures and equipment used to inspect the bridge should be documented. In most instances, it is advantageous to inspect structures in the same sequence as the load path (i.e., the deck first, then the superstructure, and finally the substructure). This manual is organized and presented in that sequence.

Many inspections cannot follow this sequence due to traffic and lane-closure restrictions. It is useful to document whatever sequence was used during the inspection. This information will be useful in planning future inspections and will also serve as a checklist to make sure that all elements and components were inspected. The following information should be included:

- Equipment required (e.g., hammers and plumb bobs)
- Access equipment (e.g., rigging, ladders, and free climbing)
- Access vehicles (e.g., inspection cranes and bucket trucks)
- Traffic restrictions (e.g., lane closures, flagmen, and hours of operation)
- Permits required (e.g., railroad and Coast Guard)
- Inspection methods (e.g., corings and ultrasonic)
- Personnel (e.g., by name and classification)
- Special equipment (e.g., material testing and underwater inspection)
- Deviations from “hands-on” inspection of all areas
- Time required for inspection
- Channel profiles and scour criticality

When structure plans are not in the bridge records and a load rating has not been calculated, it may be necessary to obtain field measurements to permit calculation of the load capacity of the structure.

Inspection Results

Narrative descriptions of the conditions should be both quantitative and qualitative, indicating the locations and the extent of the affected areas. Use forms consistent with similar inspections. Note all signs of distress, failure, or defects with sufficient precision so that a deterioration rate can be determined. This is very important for determining estimated remaining life and an optimal improvement strategy. Take photographs in the field to show defects and cross reference in the report or on forms where defects are noted. Supplement written notes with sketches and photos to show location and physical characteristics of deficiencies.

Note any load, speed, or traffic restrictions on the bridge. Include information about high water marks and unusual loadings. Note the weather conditions such as temperature, rain, or snow. All work or repairs to the bridge since the last inspection should be noted. Verify or obtain new dimensions when improvement work has altered the structure. New streambed profiles and cross sections should be taken with each inspection to detect scour, channel migration, or channel aggradation and degradation.

The seriousness and amount of all deficiencies must be clearly stated. In emergency situations, the inspector should immediately contact the inspection supervisor and the representative of the bridge owner.

Load Rating Summary

A summary of any load capacity rating analysis that has been performed should be included in the report. The summary should be presented in a table or chart. Governing load ratings should be shown for both inventory and operating levels for all types of loadings used in the analysis. The governing member for each rating should be identified. The governing member is the one that has the lowest capacity for a given type of loading.

For example, in a Girder-Floorbeam-Stringer structure, Stringer 3 in Bay 5 may have the lowest capacity for carrying HS20 trucks, compared to all other stringers, floorbeams, or girders. The HS20 inventory and operating ratings for this stringer would be reported, and it would be identified as the governing member.

Conclusions and Recommendations

A good inspection report should explain in detail the type and extent of any deterioration found on the bridge and should point out any deviations or modifications that are contrary to the “as-built” construction plans. The depth of the report should be consistent with the importance of the deterioration. Not all conditions of deterioration are of equal importance. For example, a crack in a prestressed concrete box beam which allows water to enter the beam is much more serious than a vertical crack in an abutment backwall or a spall in a corner of a slopewall.

The inspector, in formulating conclusions for the cause of the defect, must report the seriousness of the defect or deficiency involved. The inspector’s experience and judgment are called upon when interpreting inspection results and arriving at reasonable and practical conclusions. Improper and misinformed conclusions will lead to improper recommendations. The inspector may need to play the role of a detective to conclude why, how, or when certain defects occurred. When the inspector cannot interpret the inspection findings, the advice of more experienced personnel should be sought.

The recommendations made by the inspector constitute the “focal point” of the operation of inspecting, recording, and reporting. The inspector must review previous inspection recommendations and identify any that have not been addressed, particularly if urgent. A thorough, well documented inspection is essential for making informed and practical recommendations to correct or preclude bridge defects or deficiencies.

All recommendations for maintenance work, stress analysis, postings, further inspection, and repairs should be included. The inspector must carefully consider the benefits to be derived from making repairs and the consequences if the suggested repairs are not made. The inspector should list, in order of greatest urgency, any repairs that are necessary to maintain structural integrity and public safety. Recommendations concerning repairs may be classified into two general categories:

- Urgent repairs
- Programmed repairs (i.e., those to be performed sometime later)

The inspector must decide whether a repair is urgent. Usually this is easily determined, but occasionally the experience and judgment of a Professional Engineer may be required to reach a proper decision. A large hole through the deck of a bridge obviously needs attention, and a recommendation for emergency repair is in order. By contrast, a slightly deteriorated gusset plate at a panel point of a truss may not be critical. A condition such as this would appropriately call for a recommendation for a programmed repair.

Typically, most recommendations concerning repairs submitted by the bridge inspector will be in the category of programmed repairs (i.e., repairs that will be

incorporated into preprogrammed repair and maintenance schedules). Whenever recommendations call for bridge repairs, the inspector must carefully describe the type of repairs that are needed, the scope of work to be done, and an estimate of the quantity of materials that will be required.

If not already described in the executive summary, the conclusions and recommendations section of the report should summarize the following:

- Overall condition
- Major deficiencies
- Load-carrying capacity
- Recommendations for:
 - Further inspection
 - Maintenance
 - Repairs
 - Painting
 - Posting
 - Rehabilitation
 - Replacement

Some state and local agencies designate separate personnel to prepare recommendations and cost estimates.

Report Appendices

The appendices should contain any back-up information that can be used to substantiate the inspector's conclusions and recommendations. As a minimum, the appendix should include photographs, drawings and sketches, and inspection forms (see Topic 4.3 for record keeping and documentation). It can also include copies of any field notes used and specialist reports (e.g., underwater, nondestructive testing (NDT), and survey), or these documents can be referenced in the report. The appendices may also include a load capacity rating analysis of the structure.

Photographs

Photographs will be of great assistance to anyone reviewing reports on bridge structures. It is recommended that pictures be taken of any problem areas that cannot be completely explained by a narrative description. It is better to take several photographs that may be unessential than to omit one that could cause misinterpretation or misunderstanding of the report. At least two photographs of every structure should be taken. One of these should depict the structure from the roadway, while the other photo should be a view of the side elevation. Also, photographs should be inserted on sheets that are the same size as the report pages. Captions should be provided for each photo, and photos should be numbered so that they can be referred to in the body of the report.

Drawings and Sketches

Sketches should be used freely as needed to illustrate and clarify conditions of structural elements. Original drawings are very helpful during future investigations with determining the progression of defects and to help determine any changes and their magnitude. Drafting-quality plans and sketches, sufficient to indicate the layout of the bridge and bridge site, should be included as an

appendix.

Inspection Forms

The inspection forms should contain the actual field notes, as well as the numerical condition and appraisal ratings by the inspector. The inspection forms must be signed by the inspection team leader. A complete SI&A form or equivalent should be included in the appendix. If a previous report or printout is used for inventory data, items should be field checked for accuracy.

Load Capacity Analysis

Stress analysis is frequently performed on the structure to determine the load capacity of the bridge. It should include investigation of all primary load-carrying members of the bridge. Such analysis is normally performed by engineers in the office, not by the inspector. Also, not all inspections require stress analysis.

Field Inspection Notes

The original notes taken by the inspectors in the field or photocopies thereof should be included in the appendix section of the report. The original field notes are source documents and as such should be included in the bridge record.

Underwater Inspection Report

If an underwater inspection of the substructure has been performed, a separate report is usually prepared by the diver. If applicable, the diver's report should be included in the appendix.

Material Testing Results

Material testing may be performed on a structure in order to determine the strength and properties of an unknown or suspect material. The testing lab's report should be included in the appendix of the bridge inspection report.

To achieve maximum effectiveness, each report should be supplemented with sketches, photographs, or any other additional explanatory information. Reports and supplemental information must be accurate, and descriptions or explanations should be clear and concise as the report is a legal document.

4.4.3

Importance of the Inspection Report

Source of Information

A well prepared report will not only provide information on existing bridge and bridge site conditions, but it also becomes an excellent reference source for future inspections, comparative analyses, and bridge study projects. Any conditions that are suspicious but unclear should be reported in a factual manner, avoiding speculation. Terms such as "Hazardous" or "Dangerous" are subjective and should not be used in the inspection report. Further action on such reports will be determined after review and consultation by experienced personnel.

Legal Document

In preparing an inspection report, keep in mind that bridge funding may be allocated or repairs designed based on this information. Furthermore, the inspection report is a legal record which may form an important element in future litigation. The language used in reports should be clear and concise and, in the interest of uniformity, care should be taken to avoid ambiguity of meaning. The information contained in reports is obtained from field investigations, supplemented by reference to “as-built” or “field checked” plans. The source of all information contained in a report should be clearly stated.

The inspector should sign and date the inspection forms and condition reports as they are completed. No undocumented alterations should be made to the report once it is completed. Some inspectors retain copies of their reports for their personal files in the interest of self-protection should there be any litigation.

Critical Areas

A primary purpose of the inspection report is to provide guidance for immediate follow-up inspections or action. NBIS regulations require follow-up on critical findings. An agency wide procedure must be established to assure that critical findings are addressed in a timely manner. The FHWA must be periodically notified of the actions taken to resolve or monitor the critical finding. Advanced inspection techniques for one or more elements may be recommended. The report provides information which may lead to decisions to limit the use of or to close to traffic, any bridge which the inspection has revealed to be hazardous to public safety.

Maintenance

Another purpose of the inspection report is to provide useful information about the needs and effectiveness of routine maintenance activities. An active preservation program is vital to the long-term structural integrity of a bridge. The inspection report enables bridge maintenance to be programmed more effectively through early detection of structural defects or deficiencies, thus minimizing repair costs.

Load Rating Analysis

When an inspection reveals defects or deficiencies that may affect the load carrying capacity of the structure, it should be reviewed by an engineer to determine if a revised stress analysis is needed. Any new stress analysis is made to determine the safe load capacity for the current condition. It may then be necessary to restrict loads crossing the bridge so that its safe load capacity is not exceeded. It is important that the calculations for the revised load-carrying capacity analysis become part of the bridge record.

Bridge Management

Another purpose of the inspection report is analysis by the states and the FHWA of the SI&A data. The intent of the analysis is to aid in the decisions for allocating and prioritizing funding.

4.4.4

Quality

The accuracy and uniformity of information collected and recorded is vital for the management of an owner’s bridges for rehabilitation, maintenance, replacement, and, most importantly, public safety. Quality cannot be taken for granted. The responsibility of ensuring quality bridge inspections rests with each bridge owner. Two phrases are frequently used when discussing quality; they are quality control and quality assurance.

NBIS regulations require each state to assure that systematic quality control (QC) and quality assurance (QA) procedures are being used to maintain a high degree of

accuracy and consistency in the inspection program.

Bridge owners and inspectors may use established quality measures or develop their own procedures for FHWA approval.

See Topic 1.3 for a detailed description of quality control and quality assurance.

Table of Contents

Section 4	
Bridge Inspection Reporting System		
4.5	AASHTO Commonly Recognized (CoRe) Elements	4.5.1
4.5.1	Introduction.....	4.5.1
4.5.2	CoRe Element Development.....	4.5.1
4.5.3	Element Level Rating Terminology.....	4.5.2
	CoRe Elements	4.5.2
	Condition State	4.5.2
	Sub-Elements.....	4.5.2
	Non-CoRe Elements.....	4.5.2
	Smart Flags.....	4.5.2
	Feasible Actions	4.5.2
4.5.4	Basic Requirements of CoRe Elements	4.5.3
4.5.5	CoRe Element Identification.....	4.5.4
	CoRe Elements	4.5.4
	Sub-Elements.....	4.5.7
	Smart Flags.....	4.5.8
	Non-CoRe Elements.....	4.5.8
4.5.6	Condition States	4.5.9
4.5.7	Environments	4.5.10
4.5.8	The Role of CoRe Elements in Bridge Management Systems.....	4.5.10

This page intentionally left blank

Section 4

Bridge Inspection Reporting System

Topic 4.5 AASHTO Commonly Recognized (CoRe) Elements

4.5.1

Introduction

Managers of large inventories of infrastructure assets need a tool to effectively manage these assets. For bridge data, element level inspection has been successfully used as a basis for data collection, performance measurement, resource allocation, and management decision support. While NBIS (National Bridge Inspection Standards) provided a consistent standard for safety inspection of bridge sites, it was not comprehensive enough to provide performance-based decision support.

The Pontis CoRe (Commonly Recognized) Element Report, which is the basis of the AASHTO CoRe Element Guide, was prepared by technical working group representatives from California, Colorado, Minnesota, Oregon, Virginia, Washington, and the Federal Highway Administration, June 1993 explains the reasoning behind the selection of bridge items that require inspection for a successful Bridge Management System. Pontis is 'bridge' in Latin.

4.5.2

CoRe Element Development

In developing a system for standardized data collection, the FHWA and Caltrans needed to look at the shortcomings of NBIS data. The problems with NBIS data included:

- Each bridge is divided into only four major parts for condition assessment: deck, superstructure, substructure and culvert.
- The rating scale for these parts is 0-9 by severity of deterioration, which does not indicate the exact extent of the deterioration.
- The condition ratings are based on subjective interpretation by the inspectors.
- Sufficiency rating, based on NBIS data, is used by the Federal government for funding allocation. This emphasizes large scale functional and geometric characteristics of bridges, making it irrelevant for maintenance decision-making.

A system was developed which included a standardized description of bridge elements at a greater level of detail. The FHWA created a task force to revise the standards and created a manual called "*Commonly Recognized (CoRe) Structural Elements*". The AASHTO Guide for CoRe Element Manual defines each element, the unit of measurement, definitions of a set of 3-5 standardized condition states, and feasible actions for each condition state. The CoRe Element Manual was accepted as an official AASHTO manual in May 1995. The states may develop their own CoRe Element Manual based on the AASHTO manual. Approximately 40 states use element level inspection.

4.5.3

Element Level Rating Terminology

The AASHTO "Guide for Commonly Recognized (CoRe) Structure Elements" provides a description of structural elements that are commonly used in highway bridge construction and encountered on bridge safety inspections.

Many states have adopted AASHTO or modified guidelines to the Element Level Rating Guide.

There are six specific terms used to describe bridge elements in AASHTO:

- CoRe Elements are used nationwide to describe these structural bridge elements. They provide a uniform basis for data collection to share among states.
- Condition State is used to describe deterioration and defects in CoRe Elements. It's important that the various agencies that use AASHTO Element Level descriptions are consistent with one another.
- CoRe Elements can be subdivided into Sub-Elements to provide flexibility to track variations in cost or performance characteristics of the CoRe element. Physical size, location and exposure may be reasons to subdivide to Sub-Elements.
- Non-CoRe Elements are elements that are not included in the CoRe Element list were identified by the Pontis Task Force in 1993. Tunnels, Rigid Frames, Culvert Headwalls and Wingwalls, and steel secondary members are a few examples of Non-CoRe Elements which may be added by owner agency.
- Smart Flags are used to identify local problems that are not reflected in the CoRe element condition state language. They allow states to track distress conditions in elements that do not follow the same deterioration pattern or do not have the same units of measure as the distress described in the CoRe element.
- Feasible Actions provide guidance in typical repair strategies. Feasible actions are associated with each condition state for each element. The inspector is not required to record feasible actions.

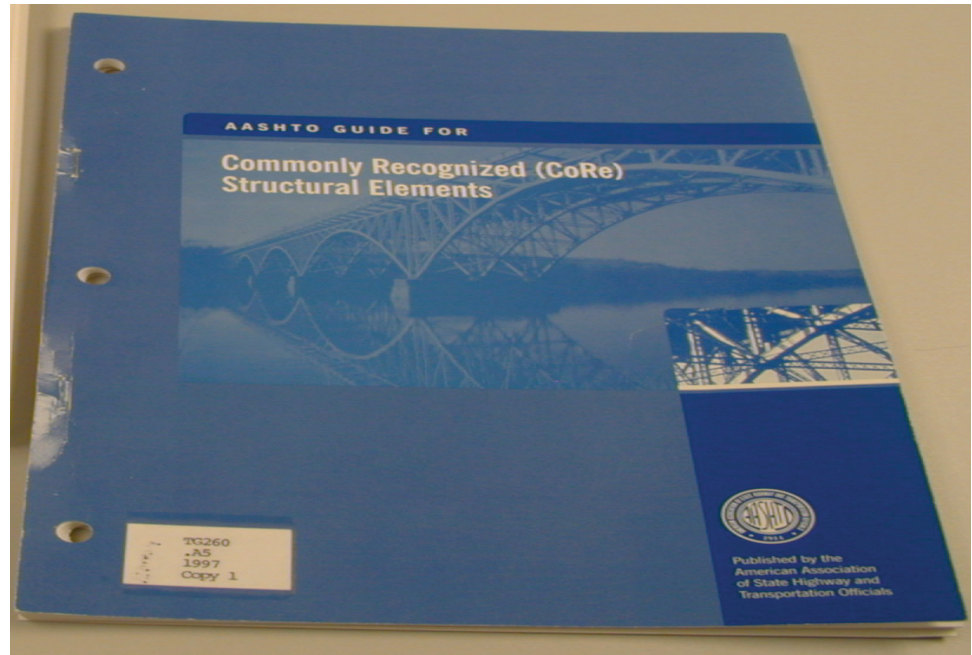

Figure 4.5.1 AASHTO CoRe Element Guide

4.5.4

Basic Requirements of CoRe Elements

In the development of CoRe elements, it was important that the specification must be generic. Different agencies have varying maintenance practices, funding mechanisms, policy concerns and terminology. However, the physical components of bridges and deterioration processes are not unique. Agencies must be able to customize the generic standard to satisfy their own purposes without sacrificing the benefits of a common standard. Any changes to elements could introduce incompatibility between agencies.

To avoid this happening, the CoRe element specification provides the ability of an agency to add its own sub-elements or non-CoRe elements. It is possible for a future CoRe Element Task Force to add new elements or sub-elements. These elements must be permanent, have clear distinction and be defined as concisely as possible. The guidelines for developing CoRe elements or sub-elements includes:

- Each element must have a unique functional role.
- Distinguish elements that have significantly different maintenance requirements.
- Distinguish elements that are measured in different ways for costing or inspection.
- Distinguish elements whose conditions are described in different ways.
- Each element must be significant from the standpoint of maintenance cost or functionality. This is why, for example, secondary members are omitted from the list of CoRe elements. The level of detail in data collection would be too large relative to the effect of these elements on decision making.
- Deterioration behavior and maintenance alternatives for the element must be sufficiently understood.
- If an element is more significant than other elements, its behavior or condition description is complex, the element may be subdivided into

smaller elements.

- A formal definition of each element must be developed to clarify thinking.

One primary use of definitions is to establish a useful inventory. In the field, each element must be clearly identified, measured and counted economically. It is also important to describe element attributes, such as size, material, condition and serviceability, quantitatively. The commonality aspect of CoRe elements depends on having definitions that are widely understood and are stable over time. One major factor contributing to definitions being widely understood is NHI's Bridge Inspector Training Course.

4.5.5

CoRe Element Identification

CoRe Elements

Ninety-eight AASHTO CoRe Elements are used to describe structural members such as:

- Girders
- Trusses
- Arches
- Cables
- Floorbeams
- Stringers
- Abutments
- Piers
- Pins and Hangers
- Culverts
- Joints
- Bearings
- Railings
- Decks
- Slabs

See Figures 4.5.2 - 4.5.5 for a list of decks/slabs, superstructure, substructure and other super/substructure AASHTO CoRe Elements.

Eight AASHTO Smart Flags are used to provide additional and possibly localized information on the CoRe elements (See Figure 4.5.6).

CoRe ELEMENT TABLE			
DECK/SLABS			
CoRe Element	Units	Element Number (Decks)	Element Number (Slabs)
Concrete (Bare)	EA	12	38
Concrete Unprotected with AC Overlay	EA	13	39
Concrete Protected with AC Overlay	EA	14	40
Concrete Protected with Thin Overlay	EA	18	44
Concrete Protected with Rigid Overlay	EA	22	48
Concrete Protected with Coated Bars	EA	26	52
Concrete Protected with Cathodic System	EA	27	53
Steel—Open Grid	EA	28	
Steel—Concrete Filled Grid	EA	29	
Steel—Corrugated/Orthotropic/Etc.	EA	30	
Timber (Bare)	EA	31	54
Timber Protected with AC Overlay	EA	32	55

EA = Each

The Deck/Slab CoRe Elements listed below by category have common condition state descriptions and feasible actions.

Figure 4.5.2 Deck / Slab CoRe Elements for AASHTO “Guide for Commonly Recognized (CoRe) Structural Elements”, page 9

Many agencies have decided to use “square meters” or “square feet” instead of “each”, although the entire deck area must be placed in one condition state.

CoRe ELEMENT TABLE							
SUPERSTRUCTURE							
CoRe Element	Units	Steel Unpainted	Steel Painted	P/S Conc	Reinf Conc	Timber	Other
Closed Web/Box Girder	m	101	102	104	105		
Open Girder/Beam	m	106	107	109	110	111	
Stringer (stringer-floor beam system)	m	112	113	115	116	117	
Through Truss (bottom chord)	m	120	121				
Through Truss (excluding bottom chord)	m	125	126				
Deck Truss	m	130	131				
Timber Truss/Arch	m					135	
Arch	m	140	141	143	144		145
Cable (not embedded in concrete)	EA	146 *	147 **				
Floor Beam	m	151	152	154	155	156	
Pin and Hanger Assembly	EA	160	161				

* Denotes uncoated steel
 ** Denotes coated steel
 EA = Each
 m = meter

Figure 4.5.3 Superstructure CoRe Elements for AASHTO “Guide for Commonly Recognized (CoRe) Structural Elements”, page 18

CoRe ELEMENT TABLE							
SUBSTRUCTURE							
CoRe Element	Units	Steel Unpainted	Steel Painted	P/S Conc	Reinf Conc	Timber	Other
Column or Pile Extension	EA	201	202	204	205	206	
Pier Wall	m				210		211
Abutment	m				215	216	217
Submerged Pile Cap/Footing	EA				220		
Submerged Pile	EA	225		226	227	228	
Pier Cap	m	230	231	233	234	235	
Culvert	m	240			241	242	243

EA = Each
 m = meter

Figure 4.5.4 Substructure CoRe Elements for AASHTO “Guide for Commonly Recognized (CoRe) Structural Elements”, page 18

CoRe ELEMENT TABLE							
OTHER SUPER/SUBSTRUCTURE							
CoRe Element	Units	Metal Coated	P/S Conc	Reinf Conc	Timber	Other	Metal Uncoated
Strip Seal Expansion Joint	m					300	
Pourable Joint Seal	m					301	
Compression Joint Seal	m					302	
Assembly Joint/Seal (modular)	m					303	
Open Expansion Joint	m					304	
Elastomeric Bearing	EA					310	
Movable Bearing (roller, sliding, etc.)	EA					311	
Enclosed/Concealed Bearing	EA					312	
Fixed Bearing	EA					313	
Pot Bearing	EA					314	
Disk Bearing	EA					315	
Approach Slab w/ or w/o AC Overlay	EA		320	321			
Bridge Railing	m	330		331	332	333	334

Ea = Each
 m = meter

Figure 4.5.5 Other Super/Substructure CoRe Elements for AASHTO “Guide for Commonly Recognized (CoRe) Structural Elements”, page 18

Sub-Elements

Sub-Elements are defined by the owner or agency. They are a subdivision of the CoRe Elements and allow a more detailed classification. They are often created to distinguish a different size, location or exposure.

- Fascia girders and interior girders can be examples of Sub-Elements.
- The ends of girders can be examples of Sub-Elements.

CoRe ELEMENT TABLE		
SMART FLAGS		
Smart Flag	Units	Element #
Steel Fatigue	EA	356
Pack Rust	EA	357
Deck Cracking	EA	358
Soffit (or undersurface) of Concrete Deck or Slab	EA	359
Settlement	EA	360
Scour	EA	361
Traffic Impact	EA	362
Section Loss	EA	363

EA = Each

Figure 4.5.6 Smart Flags for AASHTO “Guide for Commonly Recognized (CoRe) Structural Elements”, page 35

Smart Flags

Smart Flags are used to identify local problems that are not reflected in the CoRe element condition state language. Smart Flags allow agencies to track deficiencies that do not follow typical deterioration rates of CoRe elements. The NBI translator program uses Smart Flag information to help translate CoRe element level information to NBI condition data.

The unit of measurement of Smart Flags is one “Each”.

Steel Fatigue: Condition state language addresses bridges with steel elements showing fatigue damage.

Pack Rust: Rust between steel plates, including built-up members and connections.

Deck Cracking: Cracking on the top surface of concrete decks.

Soffit: Condition state language addresses the bottom or undersurface of decks. This Smart Flag is extremely valuable when the top surface of the deck is covered with an overlay.

Settlement: Substructure distress due to foundation movement.

Scour: Presence of scour and its impact on the structure.

Traffic Impact: Address distress to elements due to traffic impact damage (mainly superstructure elements).

Section Loss: Condition state language addresses section loss of structural members and indicates the degree of distress and repair status.

Non-CoRe Elements

Some agencies track items not included in the AASHTO CoRe elements list. These are referred to as Non-CoRe Elements.

Some highway structures and some features of highway structures were not

included in the AASHTO CoRe Element list. These include:

- Tunnels
- Rigid Frames
- Slope Protection
- Wingwalls and Headwalls
- Lateral Bracing
- Diaphragms
- Connectors of Steel Elements
- Waterway Protection
- Caps with Epoxy Coated Reinforcing

In general, these elements do not meet the definition for CoRe elements.

Detailed reasoning why these are Non-CoRe elements is listed on page 3 of the AASHTO “Guide for Commonly Recognized (CoRe) Structural Elements”.

Agencies are free to track these and other elements if they define them as Non-CoRe Elements.

4.5.6

Condition States

An immediate application of CoRe elements is the collection and analysis of performance data. It is essential that original data collection be as objective and repeatable as possible. This raw, objective data must be stored so that the analysis may be updated or improved at a later time. The scale of good-fair-poor-critical is not acceptable because these terms do not have precise definitions that can be observed in the field. It was decided to measure bridge condition on a single scale that reflects common processes for deterioration and the effect on serviceability. The general pattern for a CoRe Element having five condition status is as follows:

1. Protected – Protective systems sound and functioning to prevent deterioration
2. Exposed – Protective systems partially or completely failed
3. Attacked – Element experiencing active attack, but not yet damaged
4. Damaged – Element has lost material such that serviceability is suspect
5. Failed – Element no longer serves intended function.

Each of these levels of deterioration is called a condition state. The condition state methodology provides two types of information about a bridge element’s deterioration:

- Severity – characterized by precise definition of each condition state
- Extent – the distribution of the element among condition states

The severity is important for selection of a feasible and cost effective maintenance treatment, and extent is important for cost estimation.

Condition state summaries developed from narrative descriptions and quantities are developed for the CoRe Element. The information from the narrative

quantities and condition state summaries are then used to complete the element level condition report. Element Level Smart Flags are used to describe a condition which is not included in the CoRe Element condition state language.

4.5.7

Environments

Element level rating contains four environments, which describe different weather or operating conditions. The environments are important for accurate deterioration models and prediction of future conditions. The four environments are defined as follows:

1. Benign – No environmental conditions affecting deterioration
2. Low – Environmental conditions create no adverse impacts, or are mitigated by past non-maintenance actions or highly effective protective systems
3. Moderate – Typical level of environmental influence on deterioration
4. Severe – Environmental factors contribute to rapid deterioration. Protective systems are not in place or are ineffective

Environment policies are used for element level inspection and set by individual state agencies.

4.5.8

The Role of CoRe Elements in Bridge Management Systems

CoRe elements must be usable to support management decision making. The large volume of raw data collected must be transformed into useful information. For this reason, the development of bridge CoRe elements was heavily influenced by the parallel development of Pontis software.

Condition state data provides a direct indication of physical performance of bridge elements. Also, the effects of treatment actions can be tracked over time. Potential applications for agencies includes:

- Development and testing of new maintenance techniques
- Treatment selection policies
- Project priority setting and programming
- Budgeting
- Funding allocation
- Long-range planning